

Multiscale Retinex with Data-dependent Offset

Go Tanaka, Noriaki Suetake, and Eiji Uchino

Graduate School of Science and Engineering, Yamaguchi University
 1677-1 Yoshida, Yamaguchi, 753-8512 Japan

E-mail: tanaka@ic.sci.yamaguchi-u.ac.jp, {suetake, uchino}@sci.yamaguchi-u.ac.jp

Abstract—As one of methods to improve the image quality, there is a method called multiscale retinex (MSR) which has been proposed by D.J. Jobson et al. In MSR, the reflection components of an image are extracted and emphasized, and then the image with improved quality is obtained. This method is very useful and powerful especially for the visibility improvement of dark regions of the image. However, the resulting image tends to give us the unnatural impression because luminance components are removed, and the global contrast of the image is decreased in the processing. In this paper, a new MSR with a variable offset, which changes dependently on the local luminance information of the image, is proposed in order to overcome the disadvantage of the conventional MSR, and to further improve the image quality. Through the experiments, the effectiveness of the proposed method is illustrated.

I. INTRODUCTION

As one of methods for image quality improvement in a field of the digital image processing, there is a multiscale retinex (MSR) which has been proposed by D.J. Jobson et al [1].

In MSR, reflection components of an image are extracted, and then emphasized by using a linear function including gain and offset parameters. Then, the emphasized reflection components are output as a final output of MSR. The linear function including gain and offset parameters, which are constant for a whole image in the processing, is used to confine pixel values in a range [0, 255].

MSR can improve the visibility of the objects especially in the dark regions due to underexposure. However, an output image tends to be low contrast globally, and to give us unnatural impression because luminance components of the image are removed in the extraction process of the reflection components .

In this paper, we propose a new MSR with a variable offset to obtain the image, which provides the high visibility and gives us natural impression. In the proposed method, an offset of the linear function is decided dependently on the local luminance information of the image of concern. The validity and the effectiveness of the proposed method are verified by applying it to the image quality improvement of underexposed digital images.

II. CONVENTIONAL MULTISCALE RETINEX

In the conventional MSR, at first, an input image is convoluted with Gaussian functions with different scales. Then, a retinex output is obtained by calculating a logarithm of a ratio of the input image and the convoluted one in each scale, and retinex outputs are synthesized. Consequently, the synthesized

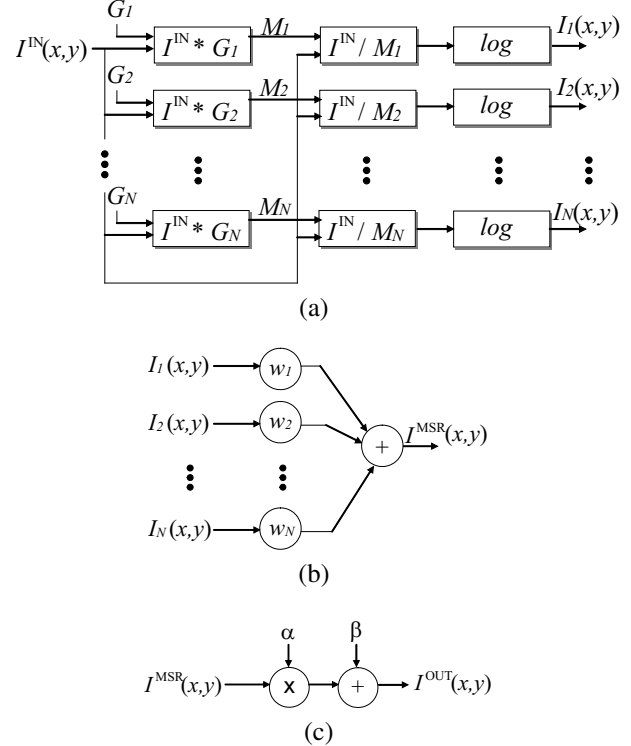

Fig. 1. Block diagram of the conventional MSR. (a) Calculation of I_n , (b) Calculation of I^{MSR} , (c) Calculation of I^{OUT} .

retinex output is processed by a linear function with gain and offset parameters, and a final output in a range [0, 255] is obtained. Figure 1 shows a block diagram of the conventional MSR.

A retinex output I_n in n -th scale is represented as follows:

$$I_n(x, y) = \log(I^{IN}(x, y)/M_n(x, y)) \quad (1)$$

with

$$M_n(x, y) = (G_n * I^{IN})(x, y), \quad (2)$$

where $I^{IN}(x, y)$ indicates the value of pixel (x, y) of an input image. \log is a natural logarithm, and $*$ is a convolution operator. Gaussian function in n -th scale is defined by:

$$G_n(i, j) = \lambda_n \exp\left(-\frac{i^2 + j^2}{2r_n^2}\right), \quad (3)$$

where λ_n is a constant for the normalization, and is determined

so that the following equation is satisfied:

$$\sum_i \sum_j G_n(i, j) = 1. \quad (4)$$

A final output image $I^{\text{OUT}}(x, y)$ is obtained as follows:

$$I^{\text{OUT}}(x, y) = \alpha I^{\text{MSR}}(x, y) + \beta \quad (5)$$

with

$$I^{\text{MSR}}(x, y) = \sum_{n=1}^N w_n I_n(x, y), \quad (6)$$

where α and β are gain and offset parameters in a linear function, respectively [1], [2]. In Eq.(6), N and w_n are the number of scales and a weight in n -th scale, respectively.

Here, we prove that the retinex processing to obtain I_n is the extraction and the emphasis of reflection components of an input image, and point out the merit and demerit of the retinex. Now, let's assume the following two assumptions:

- 1) A pixel value of I^{IN} is represented by a product of luminance component L and reflection component R [3].
- 2) M_n is in proportion to L .

These assumptions are expressed as follows:

$$I^{\text{IN}}(x, y) = L(x, y)R(x, y) \quad (7)$$

and

$$M_n(x, y) = kL(x, y), \quad (8)$$

where k means a proportionality constant. From Eqs.(1), (7), and (8), the retinex output I_n is rewritten as:

$$\begin{aligned} I_n(x, y) &= \log \frac{L(x, y)R(x, y)}{kL(x, y)} \\ &= \log R(x, y) - \log k. \end{aligned} \quad (9)$$

As shown in Eq.(9), it can be said that I_n is reflectance component R emphasized by a logarithmic function. In the retinex, even for the input image including dark regions whose visibility is extremely wrong, the output image excelled in the visibility can be obtained by reflection component emphasizing. However, an output of the retinex tends to be low contrast globally, and to give us unnatural impression due to lack of the luminance.

III. PROPOSED MULTISCALE RETINEX WITH VARIABLE OFFSET

In the proposed method, an output excelled in the visibility is obtained by addition a part of removed luminance in the retinex processing (Eq.(1)) to the MSR output I^{MSR} . Concretely, an offset β in each pixel is adaptively determined based on the local luminance components of the input image because β is related to the average luminance of an output image. Figure 2 shows the calculation process of the final output in the proposed method.

In the proposed method, a final output image I^{OUT} is obtained as:

$$I^{\text{OUT}}(x, y) = \alpha I^{\text{MSR}}(x, y) + \tilde{\beta}(x, y), \quad (10)$$

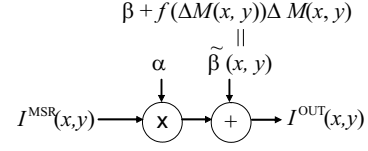

Fig. 2. Calculation process of the final output in the proposed method.

where $\tilde{\beta}$ is an offset parameter determined in each pixel. $\tilde{\beta}$ is determined as follows:

$$\tilde{\beta}(x, y) = \beta + f(\Delta M(x, y))\Delta M(x, y) \quad (11)$$

with

$$f(z) = \begin{cases} \kappa_+ & z > 0 \\ \kappa_- & \text{otherwise,} \end{cases} \quad (12)$$

$$\Delta M(x, y) = M'(x, y) - \mu, \quad (13)$$

and

$$M'(x, y) = \sum_{n=1}^N M_n(x, y)/N, \quad (14)$$

where μ is an average of pixel values of I^{IN} , and means the value proportional to the average luminance of the image. $\Delta M(x, y)$ is a difference between a luminance at (x, y) and the average luminance, and means the relative luminance. As shown in Eq.(11), $\tilde{\beta}$ is obtained by adding the compressed relative luminance $f(\Delta M(x, y))\Delta M(x, y)$ of the image. f is a function to adjust a ratio of the compression. κ_+ and κ_- are compression ratios, and real numbers in a range $[0, 1]$. When the relative luminance $\Delta M(x, y)$ is positive, κ_+ is used as a compression ratio. Otherwise, κ_- is used here.

The proposed method is consistent with the conventional MSR when $\kappa_+ = \kappa_- = 0$. That is, the proposed method can be regarded as an extension of the conventional MSR.

IV. EXPERIMENTAL RESULTS

The attempt is made to verify the validity and the effectiveness of the proposed method by applying it to the image quality improvement of some underexposed digital images. For a comparison, the conventional MSR proposed by D.J. Jobson et al. [1] and an MSR-based method proposed by Y. Takematsu et al. [4] are also employed here.

In MSR-based method, there are four parameters N , r , α , and β . In the conventional MSR, in addition to parameters mentioned above, there is a parameter w . Further, in the proposed method, parameters κ_+ and κ_- are newly added. The values of the parameters and the ways to determine them are described below.

In the experiment, parameters N and (r_1, r_2, r_3) were set as 3 and (5, 15, 25) based on Ref.[4], respectively. Further, (w_1, w_2, w_3) were set as (1/3, 1/3, 1/3) based on Ref.[1]. According to Refs.[1] and [4], it is known that 3 is enough as the value of N in many cases. However, it does not guarantee that 3 is an optimum value. Furthermore, values of standard

deviation r_n 's depends on sizes of objects in the image, though MSR-based method is designed as $(r_1, r_2, r_3) = (5, 15, 25)$ is always effective. In the experiment, these values decided above were commonly used in every method to ease an execution of comparisons.

Concerning α and β , how to determine the values is described below. From Eqs.(5) and (10), a range of pixel values of I^{OUT} is decided by the values of α and β . In order to obtain I^{OUT} excelled visually, values of α and β should be determined appropriately so that pixel values of I^{OUT} distribute in a range $[0, 255]$. In many cases, an average and a standard deviation of pixel values of I^{MSR} are almost 0 and 0.3, respectively. Further, to enhance the contrast of I^{OUT} , 128 is suitable for β . On the other hand, an average of pixel values of I^{OUT} is determined by the value of β , and the impression given by I^{OUT} becomes wrong when its average of pixel values are smaller than those of I^{IN} . Therefore, at first, β was set based on μ as follows:

$$\beta = \begin{cases} \mu & \mu > 128 \\ 128 & \text{otherwise.} \end{cases} \quad (15)$$

Then, α was determined based on the evaluation index Q , which has been proposed by D.J. Jobson et al. [5], for the image quality. To calculate Q , an image I of concern is divided into 50×50 non-overlapping blocks, and an average standard deviation $\bar{\sigma}$ over blocks is calculated after obtaining a standard deviation of pixel values in each block. $\bar{\sigma}$ reflects the strength of the contrast of I , and becomes large in the image with high contrast. Q is defined as follows:

$$Q = \bar{I} \bar{\sigma}, \quad (16)$$

where \bar{I} is an average of pixel values of I . When the visibility of the dark region of an image is improved, \bar{I} becomes large followed by the increase of the average of pixel values in that region. And the contrast of the dark region becomes high, and $\bar{\sigma}$ is also increased. Hence, Q becomes large according as an image quality, that is, the visibility is improved. It is also known that Q of the high quality image is equal to or more than 6000 [4], [5]. In the experiment, α was adjusted so that Q of an output image becomes about 6000. After the adjustment of α , 170, 240, and 120 were adopted as α in MSR, MSR-based method, and the proposed method, respectively.

Here, 0.8 and 0.4 were experimentally assigned to κ_+ and κ_- only for the proposed method, respectively.

For example, Figs.3(a), 3(b), 3(c), and 3(d) show an input image (400×300 pixels) taken in underexposure, the experimental results obtained by the conventional MSR, MSR-based method, and the proposed method, respectively. Furthermore, the magnified upper central parts of images shown in Figs.3(a), 3(b), 3(c), and 3(d) are shown in Figs.4(a), 4(b), 4(c), and 4(d), respectively. In the similar manner to Fig.4, the magnified lower left corners of images shown in Fig.3 are shown in Fig.5.

Table I shows the quantitative evaluation index Q for the images shown in Fig.3. As mentioned above, Q 's are almost equal to 6000 due to adjusting α .

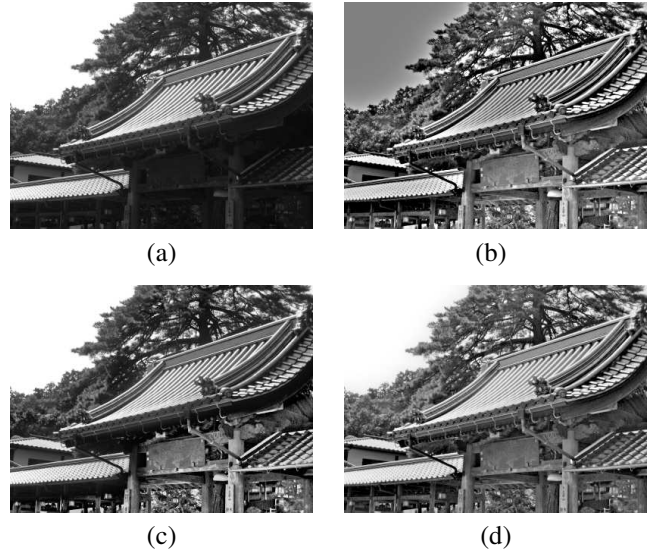

Fig. 3. Experimental result for an image taken in underexposure. (a) Input image, (b) MSR, (c) MSR-based method, (d) Proposed method.

TABLE I
EVALUATION INDEX Q .

	Q	\bar{I}	$\bar{\sigma}$
Input image	4228	93	45.6
MSR	6039	106	56.9
MSR-based method	6005	110	54.7
Proposed method	6062	122	49.8

Here, the subjective evaluation concerning the resulting images in each method are described below. As shown in Fig.3(b), the visibility of the dark regions of the image is improved by MSR. However, the global light and shade yielded by the brightness of the sky and the sunshine is lost, and then the unnatural impression is arisen. Furthermore, as shown in Fig.4(b), pixel values of leaves of tree become parti-colored and it is confirmed that the image quality is deteriorated in comparison with Fig.4(a).

In MSR-based method, the brightness of the regions, which are constituted of pixels with large values, is kept as shown in Fig.3(c). And, the brightness of leaves of the tree, which is not appropriately transformed by MSR, is also well transformed (Fig.4(c)). However, as shown in Fig.5(c), the improvement of the visibility is not performed perfectly in the left back building and the lower side of central roof, that is, boundaries of dark and bright regions, and the resulting image gives us unnatural impression. This is a phenomenon peculiar to MSR-based method. In MSR-based method, an MSR output image and an input image are mixed each other in each pixel based on the information of the input image. Concretely, the values of pixels belonging in the regions whose local average of brightness is large, or whose local contrast is high, in the input image are weighted in the mixture with the MSR output image. The local contrast is evaluated by the standard deviation of pixel values in each local region. Therefore, the local contrast at the boundary of dark and bright regions is judged as high,

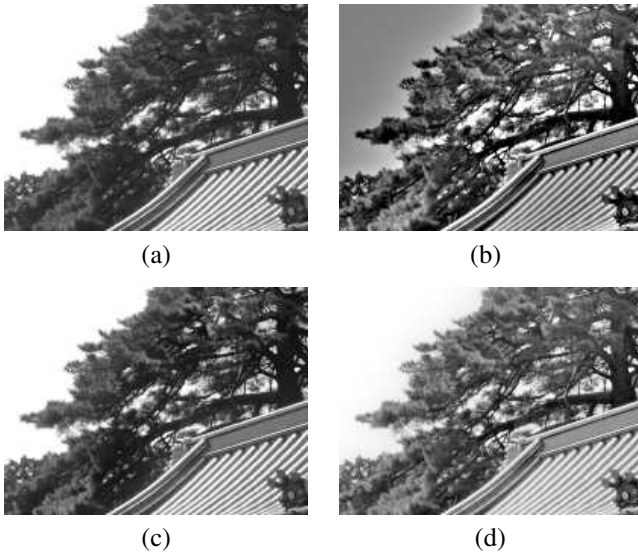

Fig. 4. Magnified upper central parts of images shown in Fig.3. (a) Input image, (b) MSR, (c) MSR-based method, (d) Proposed method.

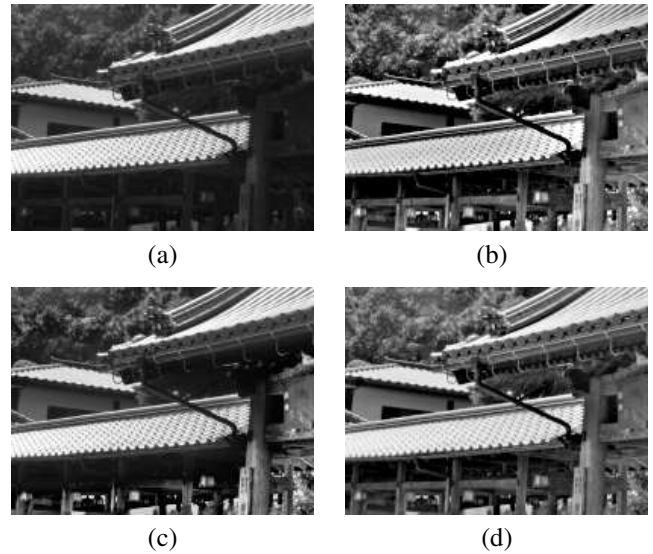

Fig. 5. Magnified lower left corners of images shown in Fig.3. (a) Input image, (b) MSR, (c) MSR-based method, (d) Proposed method.

and the values of pixels at these boundaries in the input image are adopted as the outputs.

As shown in Figs.3(d), 4(d), and 5(d), in the proposed method, the brightness of the sky is kept, a distribution of pixel values of the leaf regions is natural, and the visibility of the boundaries of dark and bright regions is also improved well. It can be said that the output image of the proposed method is excelled in the visibility, gives us a natural impression, and its quality is very high.

Furthermore, the similar results to images shown in Figs.3, 4, and 5 were obtained by the proposed method for other test images taken in underexposure.

V. CONCLUSIONS

In this paper, a new MSR with a data-dependent offset in order to obtain the image, which provides the high visibility and gives us natural impression, was proposed. In the proposed method, an offset of the linear function was decided dependently on the local luminance information of the image of concern. The validity and the effectiveness of the proposed method were illustrated by applying it to the image quality improvement of underexposed digital images.

A future work is to develop an automatic parameter adjusting algorithm which can decide values of parameters appropriately for each input image of concern.

ACKNOWLEDGMENT

This work was supported by Grant-in-Aid for Exploratory Research 19650041 by Japan Ministry of Education, Culture, Sports, Science and Technology.

REFERENCES

- [1] D.J. Jobson, Z. Rahman, and G.A. Woodell, "A multiscale retinex for bridging the gap between color images and the human observation of scenes," *IEEE Trans. Image Process.*, vol.6, no.7, pp.965–976, July 1997.
- [2] G.D. Hines, Z. Rahman, D.J. Jobson, and G.A. Woodell, "DSP implementation of the retinex image enhancement algorithm," *Visual Information Processing XIII, Proc. SPIE vol.5438*, April 2004.
- [3] D.J. Jobson, Z.Rahman, and G.A. Woodell, "Properties and performance of a center/surround retinex," *IEEE Trans. Image Process.*, vol.6, no.3, pp.451–462, March 1997.
- [4] Y. Takematsu, T. Nakaguchi, N. Tsumura, and Y. Miyake, "Improvement of image quality using retinex theory based on the statistical image evaluation," *Journal of the Society of Photographic Science and Technology of Japan*, vol.67, no.4, pp.410–416, 2004. (in Japanese)
- [5] D.J. Jobson, Z. Rahman, and G.A. Woodell, "The statistics of visual representation," *Visual Information Processing XI, Proc. SPIE vol.4736*, pp.25–35, 2002.