

Design of Data-Oriented PID Controllers
Based on Minimizing Generalized Output Errors

(一般化出力誤差の最小化に基づく)
(データ指向型PID制御器の設計)

Kayoko Hayashi

March, 2014

Acknowledgment

The work presented in this dissertation was carried out at Hiroshima University under the supervision of Professor Toru Yamamoto.

First of all, I would like to express my sincere gratitude to Professor Toru Yamamoto for his constructive advice, in-depth discussion, and incisive comments. He provided long-term support though technical help as well as precise direction, continuous encouragement, and careful comments.

I express my appreciation to Professors Ichiro Nishizaki and Toshio Tsuji for their guidance as Assistant Advisors.

I also thank Associate Professor Ohno Shuichi and Assistant Professor Masayoshi Nakamoto for their continuous helps.

I especially thank my family for their moral support and warm encouragement.

Finally, I owe thanks to all of the members of System Control Laboratory of the Department of System Cybernetics, Graduate School of Engineering, Hiroshima University.

Contents

Chapter 1	Introduction	1
1.1	Background	1
1.1.1	PID control	3
1.1.2	Data-oriented control system	6
1.2	The purpose of this study and the composition of this dissertation	7
Chapter 2	Design of a PID controller for single-input/single-output systems	9
2.1	Introduction	9
2.2	Design of a control system	10
2.2.1	The description of a system	10
2.2.2	Design of a control system	10
2.3	Simulation Examples	12
2.3.1	Second-order lag linear system	12
2.3.2	High-order lag system	24
2.3.3	Time delay system	28
2.4	Application for an injection molding system	31
2.4.1	About an injection molding system	31
2.4.2	Control results	32
2.5	Conclusions	36
Chapter 3	Design of a PID controller for multivariable systems	37
3.1	Introduction	37
3.2	Design of a control system	38
3.2.1	The description of a system	38
3.2.2	Design of a controller	38
3.3	Simulation Examples	41
3.3.1	Two-input/two-output system	41

3.3.2	Multivariable system including a time delay	55
3.3.3	Stirred reactor model	59
3.4	Conclusions	63
Chapter 4	Design of a PID controller for nonlinear systems	64
4.1	Introduction	64
4.2	Design of a control system	65
4.2.1	Data-driven control scheme	65
4.2.2	The description of a system	65
4.2.3	Proposed scheme	66
4.3	Simulation Examples	73
4.3.1	Hammerstein Model 1	73
4.3.2	Hammerstein Model 2	77
4.3.3	Hysteresis model	81
4.4	Conclusions	85
Chapter 5	Conclusions	86
	References	89
	Publications	100

Chapter 1

Introduction

1.1 Background

For real processes, such as those that take place oil and chemical plants, proportional-integral-derivative (PID) control systems^(1,2) are effective control methods. These systems have been implemented in more than 80% of control loops⁽³⁾ for industrial processes for several reasons: (1) the control structure is clear; (2) the elements of the controller constructed proportional, integral and a derivative motions, and these parameters have clear physical meanings; and (3) operators can use their experience to adjust PID gains. However, determining PID gains is important because they have a large influence on the control performance. Many adjustment methods for PID gains have been proposed⁽⁴⁻⁹⁾.

For example, Ziegler and Nichols proposed an ultimate sensitivity tuning method and step response method⁽¹⁰⁾ with focus adjusting the damping ratio of response waveform become 1/4. The Chien, Hrones & Reswick method⁽¹¹⁾ that a system can be approximated as a first-order model plus dead time, and the PID gains are determined so that the following control purpose combinations can be achieved: when the target value or disturbance changes step, the control purpose is set to non-overshoot or 20% overshoot.

However, the PID gains obtained by these methods can not be used without adjustment. They need to be calibrated empirically for implementation. Moreover, the obtained PID gains have several problems depending on the gain value: (1) an excessive overshoot occurs; (2) a settling time is longer, and (3) a steady-state characteristics are degraded. Furthermore, real plants require multiple experiment runs to obtain a set of suitable PID gains. Thus, the

experiments produce more human costs and time costs, and place a tremendous burden on plants. In addition, when PID control systems is designed, it is necessary to construct a system models in most cases. However, the system characteristics can not be identified because of the systems complexities. Therefore, the control schemes are required a high performance simple and to avoid system identification.

In the last decade, several design schemes of data-oriented controllers which do not require a system model have been considered to solve these problems^(12,13). These schemes are illustrated to be effective for to systems whose properties and structures are mostly unknown. For example, data-driven control methods such as the just-in-time method^(14,15) and memory-based method⁽⁷⁹⁾ can obtain good control performance, although the computational cost is quite high. The Iterative Feedback Tuning(IFT) method⁽¹⁶⁻¹⁸⁾, the Virtual Reference Feedback Tuning(VRFT) method⁽¹⁹⁻²¹⁾, and the Fictitious Reference Iterative Tuning(FRIT) method⁽²²⁻²⁹⁾ can directly compute control parameters using the operating data and desired step response. The advantage of these schemes is that systems are not a burden during operation because a model does not need to be described in an experiment for system identification. The IFT method searches to control parameters to reduce the value of function for an obtained output error by adding a test signal to the closed-loop system and system input in several iterations. Likewise, the VRFT method identifies control parameters, to be near a fictitious reference value determines the response for the reference model by using an input/output data set of a system. However, the IFT method requires repeated online testing, and the VRFT method needs an operating data for the open-loop. Thus, these methods are not suitable. In contrast, the FRIT method does not have these constraints and can directly obtain control parameters by using operating data and a fictitious reference signal. The method has attracted attention and has been used in many practical applications for mechanical systems⁽³⁰⁻³²⁾ and processes^(33,34). The E-FRIT^(35,36) method, which is simplified version of the FRIT method, can automatically adjust the design to reference model corresponding to a system, and a restriction parameter of input is developed to ensure a system stability, it can cover the shortcomings of the FRIT method.

1.1.1 PID control

Fig. 1.1 shows the basic form of the PID controller. The control system determines the system input so that a controlled variable for the system output is equivalent to the obtained reference signal. Here, the reference value is denoted by r , and the observation value, system output, and control input are denoted by y , z and u , respectively. The disturbance is d_1 and the noise is d_2 . For simplicity, the control input is a signal given to the system with a disturbance added, and the system output is equal to the observation value without the noise. Likewise, the error is defined as the reference value minus the system output and shows the gap between the desired output signal and the actual value. Therefore, the control input is determined according to the error

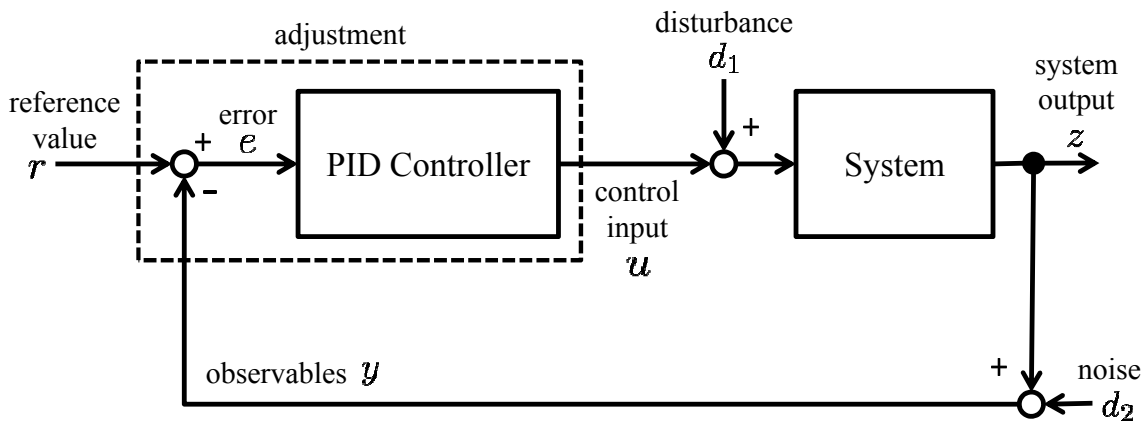

Fig. 1.1: The basic of PID controller.

PID controllers have a proportional action for the error. The P gain behaves as an error because the system error is assumed to be small if the error is small, and vice versa. However, if the P controller is applied in self-regulated systems, they could have a certain error value for a reference signal or step disturbance which is called stationary error. Self-regulation is a property where a system converges to a fixed value without being controlled does not change unilaterally. Stationary errors can be reduced by adding a term for the deviation integral. This term shows an integral action, and it is sometimes called a reset action because its purpose is to cancel stationary errors. In order to improve control properties, the control law also includes a differential term for deviation. This is called the derivative or rate actions because

it is proportional to the rate of change in the errors. The PID control law includes these three operations.

Here, the control law for a PID controller *i.e.* system input u is expressed by using error e :

$$u(t) = K_P \cdot e(t) + K_I \int_0^t e(\tau) d\tau + K_D \frac{de(t)}{dt}. \quad (1.1)$$

K_P , K_I and K_D are the proportional, integral and derivative gains. The above equation (1.1) can be rewritten as follows:

$$u(t) = K_P \left\{ e(t) + \frac{1}{T_I} \int_0^t e(\tau) d\tau + T_D \frac{de(t)}{dt} \right\} \quad (1.2)$$

where T_I denotes the integral time, and T_D denotes the derivative time. Fig. 1.2 illustrates a PID control system. If a system employs a PID controller, the design of the control system can be summarized by determining three parameters such the proportional gain, integral time and derivative time. This is called the tuning of PID control.

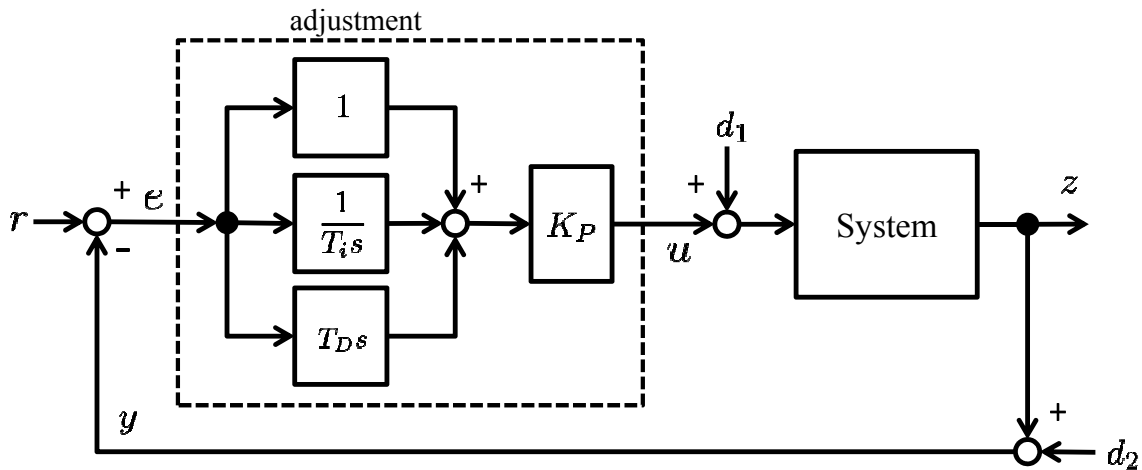

Fig. 1.2: The basic of PID controller.

In basic PID control, the case of reference value changing to a stepwise function is considered. In principle, a system output includes the delta function *i.e.* differential of the step function because of a derivative action. In fact, a system output has a sharp signal pulse instead of the delta function because the derivative element uses an inexact differential. This is called

kicking. However, it is usually impossible for an actuator to moves with the pulse, and the actuator should not be operated manually because it hen loses it advantage. A structure was considered so that the derivative action works only on y without the need to differentiate the reference signal. Similarly, the proportional action in the stepwise change of a reference signal is considered, and a control input then includes a step function by the proportional action. However, actuators such as an on-off valve should not operate in a stepwise fashion. Thus, a structure which is associated with proportional and a derivative actions using only y was considered. This is called an I-PD controller⁽³⁷⁾, and the structure is shown in Fig. 1.3.

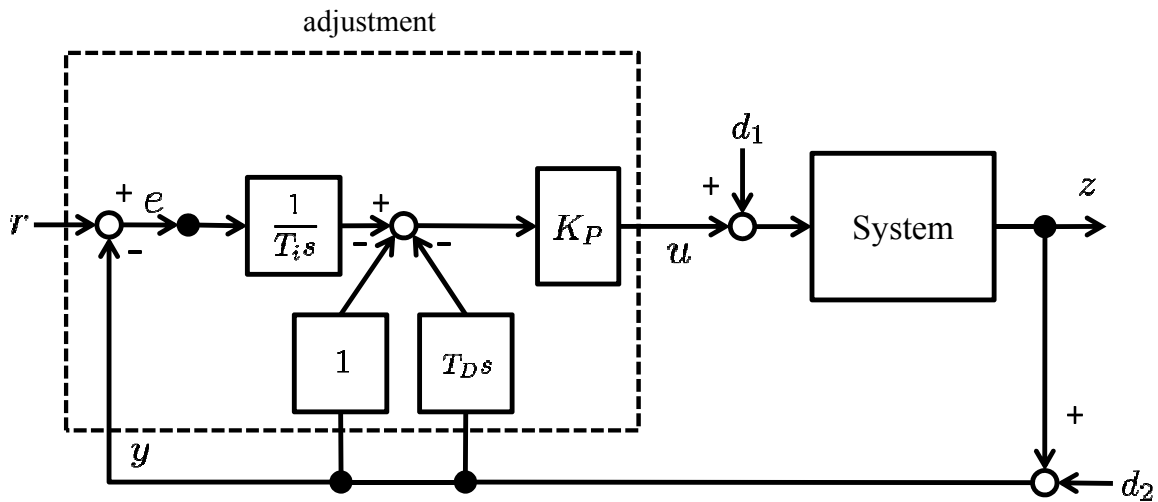

Fig. 1.3: The detail of I-PD controller

The control law is expressed as follows:

$$u(t) = K_P \left\{ -y(t) + \frac{1}{T_I} \int_0^t e(\tau) d\tau - T_D \frac{dy(t)}{dt} \right\}. \quad (1.3)$$

If the same PID parameters for a basic PID controller applied in the I-PD controller, the response of the system to changes in the reference value becomes slower because the reference signal is only associated with integral actions. For this reason, the I-PD controller is often applied to real processes which use a stepwise reference signal. Therefore, the I-PD controller is discussed in this dissertation.

1.1.2 Data-oriented control system

Recently, rapid economic growth in East Asia has spurred intense international competition. In order to enhance international competitiveness, the Japanese industry sector has emphasised improving productivity, and product quality while reducing produce cost. Greenhouse gas reduction is an important international problem, and each developed country has embarked on measures such as establishing reduction goals. In Japan, since public and corporate sectors produce 80% of the greenhouse gas emissions, companies are forced to make further efforts reduce the company. In solving these problems, the control system plays a very large role, so a high level of performance is required.

Recent developments in computer technology have made, it is possible to quickly process large amounts of data in real-time. Because storage and processing of operating data and program construction have become easy, there is renewed focus on improving the control performance.

PID control is a common and effective approach in process industries; however, it is difficult to obtained a set of suitable PID gains. Most proposed schemes use model-based controllers^(38,39). Model-based controllers are performed through system identification based on operating data. However, it is difficult to identify true system parameters because, if the system model is not described accurately, the desired control performance can not be obtained. System identification is one of topic of research on control, and many methods have been proposed⁽⁴⁰⁻⁴⁷⁾. For example, neural networks(NN)⁽⁴⁸⁾ and group method of data handling(GMDH) networks⁽⁴⁹⁾ can express nonlinear systems. However, a description model is required to explain system properties in a suitable and simple manner. An input signal needs to be identified with a high degree of accuracy to make an accurate model^(50,51), and a comfortable level of persistently exciting(PE) is required. Generally, the ideal identification input signal has all frequency elements because it needs to excite all modes of a system⁽⁵²⁾. Thus, the input signal should be given an m-sequence noise. However, exciting to the apparatus and actual plant may pose a safety risk. Terminal parts of system are strongly subject to influence by exciting because system as oil plant especially unite several systems, Moreover, the obtained gains should be adjusted by the actual system once or twice. This requires more cost and computation time.

1.2 The purpose of this study and the composition of this dissertation

The purpose of this study is to propose a data-oriented control system design scheme for practical application. The proposed scheme can directly determine PID gains from the operating data and desired control design specifications. In this scheme, the generalized output is developed from I-PD control law which is used in industrial processes, and the control system is designed from it. In detail, PID gains are optimized so that the error between the generalized output and operating data is equivalent to zero. First, the design scheme of a controller for single-input and single-output linear systems is considered, and the effectiveness of the proposed scheme is evaluated through numerical examples. The scheme is applied to the injection molding process such as a representative thermal process to verify its usefulness. However, since real processes use multivariable and nonlinear systems, expanding the proposed scheme to these systems is vital. For multivariable systems, mutual interference between the input and output can be reduced by optimizing the PID gains matrix, including non-diagonal elements. In addition, the fitness function adapts the weight parameters of each input and output, and the output is weighted based on the operating conditions and control specifications. With regard to nonlinear systems, the proposed scheme is expanded to a nonlinear controller using a data-driven control approach method, and its effectiveness is demonstrated. Although the conventional data-driven control method requires some experiments on the real system, the database can be constructed in an offline manner (*i.e.* offline learning) and then fuse with the proposed scheme.

This dissertation is organized as follows: Chapter 2 discusses defining the generalized output from PID control law and designing a controller for single-input and single-output linear systems. The effectiveness is examined through numerical examples, and the proposed scheme's viability with regard to real systems is evaluated by application to an injection molding process. Chapter 3 describes the control design method for multivariable systems. The effect of the weighting factor on the input and output in numerical simulations is considered. Chapter 4 proposes the extended method based on the concept of the data-driven control system design method for nonlinear systems. The effectiveness of the proposed method is verified through numerical examples. Finally, chapter 5 summarizes the design of a data-oriented PID controller

based on the generalized output errors, and discusses the validity of this study's results and issues for the future.

Chapter 2

Design of a PID controller for single-input/single-output systems

2.1 Introduction

Chapter 2 presents the proposed PID controller design scheme, which use only the operating data to design a data-oriented control system for single-input/single-output.

As discussed in chapter 1, if a system's structure and parameters cannot be determined, PID gains can be effectively calculated from the operating data without system identification. Because PID controllers are widely applied for many process systems, being able to directly compute PID gains using operating data is useful. In order to organize the proposed method, a single-input/single-output linear system is considered. In the proposed scheme, the generalized output is defined from a PID control law, and then, PID gains are adjusted by a optimized calculation so that the signal is equivalent to the system output of operating data.

In this chapter, the problem statement is presented first. The new proposed scheme is then discussed. The procedure of the proposed scheme is explained in detail, and the effectiveness of the proposed scheme is numerically illustrated by simulation examples. In addition, the usefulness of the proposed scheme is experimentally evaluated by applying to an injection molding process.

2.2 Design of a control system

2.2.1 The description of a system

The continuous-time PID controller has the following transfer function:

$$G(s) = k_c \left[1 + \frac{1}{T_i s} + T_d s \right] \quad (2.1)$$

where k_c denotes the gain, T_i denotes the integral time, and T_d denotes the derivative time. When the equation is discretized for a discrete-time PID controller by the sampling interval T_s , it is rewritten as follows:

$$\begin{aligned} u(k) = & u(k-1) + K_P(y(k-1) - y(k)) \\ & + K_I(r(k) - y(k)) + K_D(2y(k-1) - y(k-2) - y(k)) \end{aligned} \quad (2.2)$$

The reference signal is denoted by $r(k)$. K_P , K_I and K_D denote the proportional gain, integral gain and derivative gain, respectively. $u(k)$ and $y(k)$ are the control input and corresponding output signal. Δ denotes the differencing operator and is defined by $\Delta := 1 - z^{-1}$.

When computing these parameters, *i.e.* PID gains, the descriptive model corresponding to the controlled object is first designed using the operating input/output data. That is, the system parameters are estimated using the system identification method, *e.g.* the least squares method. PID gains are calculated using a model based on estimates. When utilizing closed-loop data, however, it is well-known that it is impossible to obtain the model with good accuracy due to the lack of the excitation of input/output data. Therefore, being able to compute the PID gains directly from the closed-loop data is desired.

In this paper, the generalized output is first derived from the PID control law, and the PID gains are calculated so that the generalized output becomes identical to the system output. The proposed method is explained below in detail.

2.2.2 Design of a control system

Equation (2.2) can be rewritten as

$$\begin{aligned} d(k) + (K_P + K_I + K_D)y(k) - (K_P + 2K_D)y(k-1) \\ + K_D y(k-2) - K_I r(k) = 0 \end{aligned} \quad (2.3)$$

where $d(k) = u(k) - u(k-1)$. By deviding both sides of equation (2.3) by K_I , the following equation is obtained:

$$\frac{d(k)}{K_I} + \frac{K_P + K_I + K_D}{K_I}y(k) - \frac{K_P + 2K_D}{K_I}y(k-1) + \frac{K_D}{K_I}y(k-2) - r(k) = 0. \quad (2.4)$$

The generalized output $\Phi(k)$ is defined as follows:

$$\Phi(k) : = a_1d(k) + a_2y(k) + a_3y(k-1) + a_4y(k-2) \quad (2.5)$$

where

$$\left. \begin{aligned} a_1 &= \frac{1}{K_I} \\ a_2 &= \frac{K_P + K_I + K_D}{K_I} \\ a_3 &= -\frac{K_P + 2K_D}{K_I} \\ a_4 &= \frac{K_D}{K_I}. \end{aligned} \right\} \quad (2.6)$$

From equations (2.4), (2.5) and (2.6), the following relation can be obtained:

$$\Phi(k) - r(k) = 0 \quad (2.7)$$

The control objective is to find suitable PID gains so that the system output $y(k)$ tracks the desired reference model output $y_m(k)$, which is defined as

$$G_m(z^{-1}) = \frac{z^{-1}P(1)}{P(z^{-1})}, \quad (2.8)$$

where

$$\left. \begin{aligned} P(1) &= 1 + p_1 + p_2 \\ P(z^{-1}) &= 1 + p_1z^{-1} + p_2z^{-2}, \end{aligned} \right\} \quad (2.9)$$

the coefficients p_1 and p_2 are determined by⁽⁵³⁾

$$\left. \begin{aligned} p_1 &= -2e^{-\frac{\rho}{2\mu}} \cos\left(\frac{\sqrt{4\mu-1}}{2\mu}\rho\right) \\ p_2 &= e^{-\frac{\rho}{\mu}} \\ \rho &:= \frac{T_s}{\sigma} \\ \mu &:= 0.25(1 - \delta) + 0.51\delta \end{aligned} \right\} \quad (2.10)$$

where T_s denotes sampling interval, and σ and μ denote the rise-time and the damping index, respectively. The reference output shape is changed by choosing σ and μ , which is adjusted by δ . σ corresponding to the rise-time can be set between $1/3 \sim 1/2$ of the time constant. Moreover, the step shape is shown as Binomial model response when δ is set to 0. and the response is shown as Butterworth model response when $\delta = 1$. If the desired output is determined in a practical way, δ should be set to 0.0 through 2.0. Furthermore, these parameters need to be determined based on system property.

When parameters a_i ($i = 1, \dots, 4$) are adjusted so that the following relation is satisfied:

$$G_m(z^{-1})\Phi(k) \rightarrow y(k), \quad (2.11)$$

then the following relationship can be obtained from equations (2.7) and (2.11):

$$y(k) \rightarrow G_m(z^{-1})r(k). \quad (2.12)$$

Therefore, the PID controller is designed as the system output tracks the reference model output. By optimizing the following cost function, the following relationship can be obtained:

$$J = \frac{1}{N} \sum_{k=1}^N \varepsilon^2(k), \quad (2.13)$$

where

$$\varepsilon(k) = G_m(z^{-1})\Phi(k) - y(k) \quad (2.14)$$

and N is the step of the operating data. In order to minimize equation (2.13), for example, the optimization toolbox in Matlab can be utilized.

Therefore, the proposed scheme can be used to design PID controller to track the reference model output. The next section, presents some numerical simulation examples which were used to evaluate the effectiveness of the proposed scheme.

2.3 Simulation Examples

2.3.1 Second-order lag linear system

First, the following discrete-time stochastic system⁽¹⁾ was considered:

$$y(k) = 0.68y(k-1) + 0.22y(k-2) + 0.26u(k-1) + 0.08u(k-2) + \xi(k) \quad (2.15)$$

where $\xi(k)$ denotes a Gaussian white noise with a zero mean and variance of 0.1^2 .

Next, the PID control scheme applied to this system. The control result is shown in Fig. 2.1, where $K_P = 0.50$, $K_I = 0.50$ and $K_D = 1.50$. Here, the desired reference signal is as follows:

$$r(k) = \begin{cases} 10.0 & (0 < k \leq 100) \\ 5.0 & (100 < k \leq 200) \\ 15.0 & (200 < k \leq 300). \end{cases} \quad (2.16)$$

The control result eventually converged to the reference value, although the output was oscillatory.

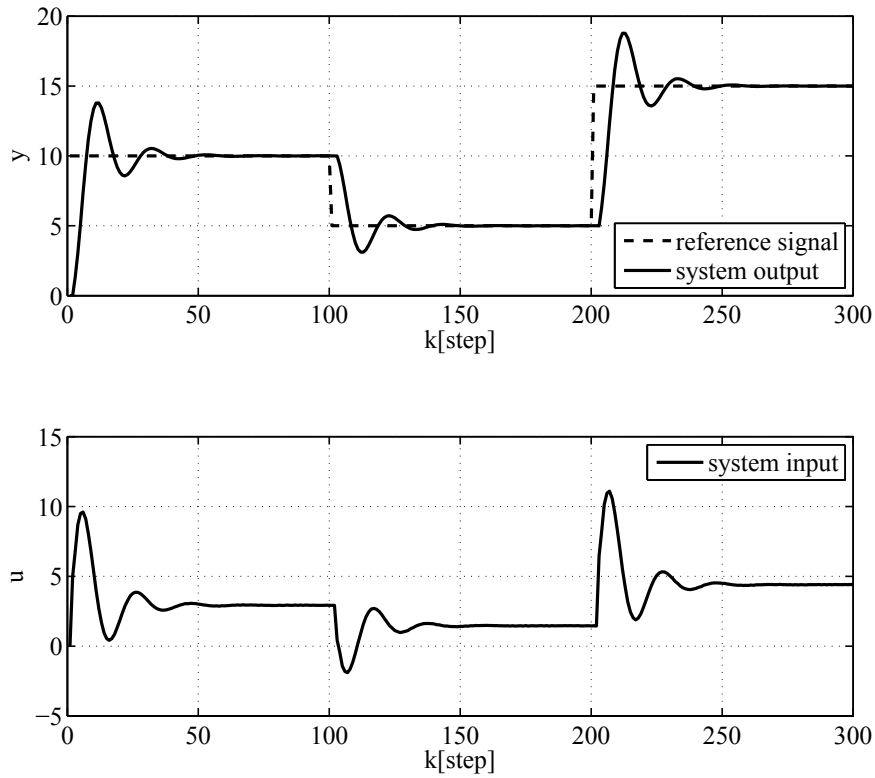

Fig. 2.1: Control result by using the PID controller where PID gains are determined by $K_P = 0.50$, $K_I = 0.50$, and $K_D = 1.50$.

Next, the proposed scheme was applied, where the desired $P(z^{-1})$ was designed by setting $\sigma = 5.0$ [s] and $\delta = 0.0$. The following polynomial was then obtained:

$$P(z^{-1}) = 1 - 1.34z^{-1} + 0.45z^{-2} \quad (2.17)$$

The control result is shown in Fig. 2.2; the computed PID gains were $K_P = 0.994$, $K_I = 0.270$, and $K_D = 0.034$.

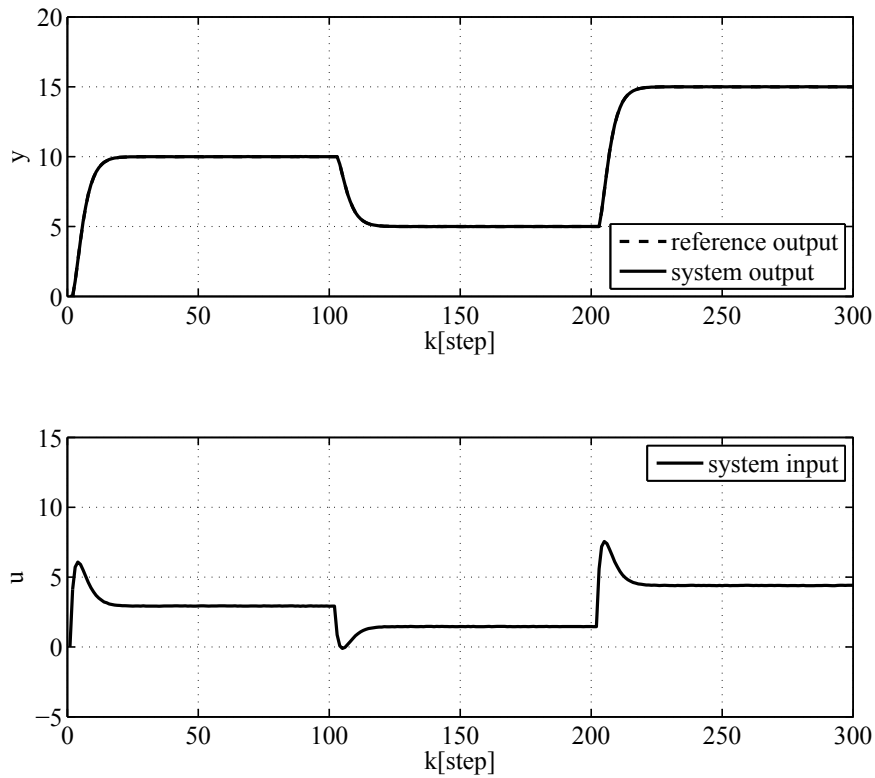

Fig. 2.2: Control result by using the proposed scheme where PID gains are determined by $K_P = 0.994$, $K_I = 0.270$ and $K_D = 0.034$.

Comparing these results, clearly showed that calculating the PID gains using the proposed scheme produced a good performance.

Next, the initial PID gains were changed to verify the computed PID gains of the proposed scheme. Different operating data were given to the proposed scheme because it is not useful if entirely different PID gains are calculated. Figs. 2.3 and 2.4 show the control results from using the PID gains in row 2 of Table 2.1. Each output was oscillatory, including an overshoot and slow curve curve. The oscillatory output data were the same as the data shown in Fig. 2.1.

Table 2.1: PID parameters corresponding to the different initial PID gains.

waveform	PID gains	K_P	K_I	K_D
overshoot	$K_P = 1.50$	0.994	0.278	0.025
	$K_I = 0.80$			
	$K_D = 1.00$			
oscillatory	$K_P = 0.50$	0.994	0.270	0.034
	$K_I = 0.50$			
	$K_D = 1.50$			
slow	$K_P = 1.00$	0.986	0.256	0.098
	$K_I = 0.07$			
	$K_D = 0.10$			

The operating data were applied to the proposed scheme, and the right side of Table 2.1 shows sets of PID gains which are computed by changing the initial PID gains.

As shown in Table 2.1, the proposed scheme was verified to compute almost the same PID gains from input/output data even if the initial PID gains are different.

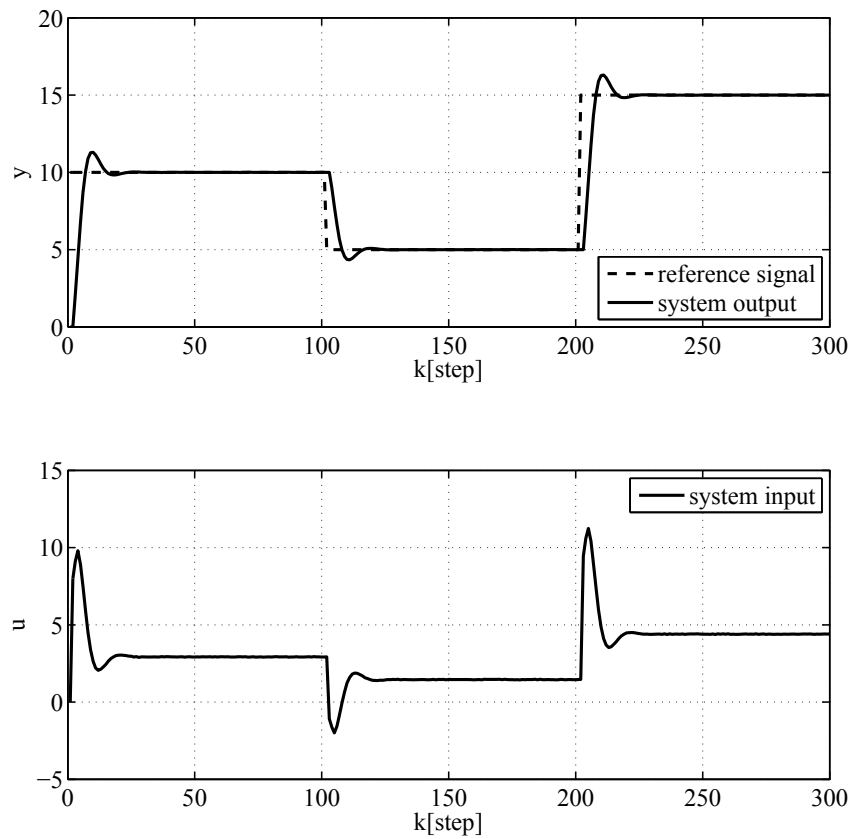

Fig. 2.3: The operating data (overshoot) when PID gains are $K_P = 1.50$, $K_I = 0.80$ and $K_D = 1.00$.

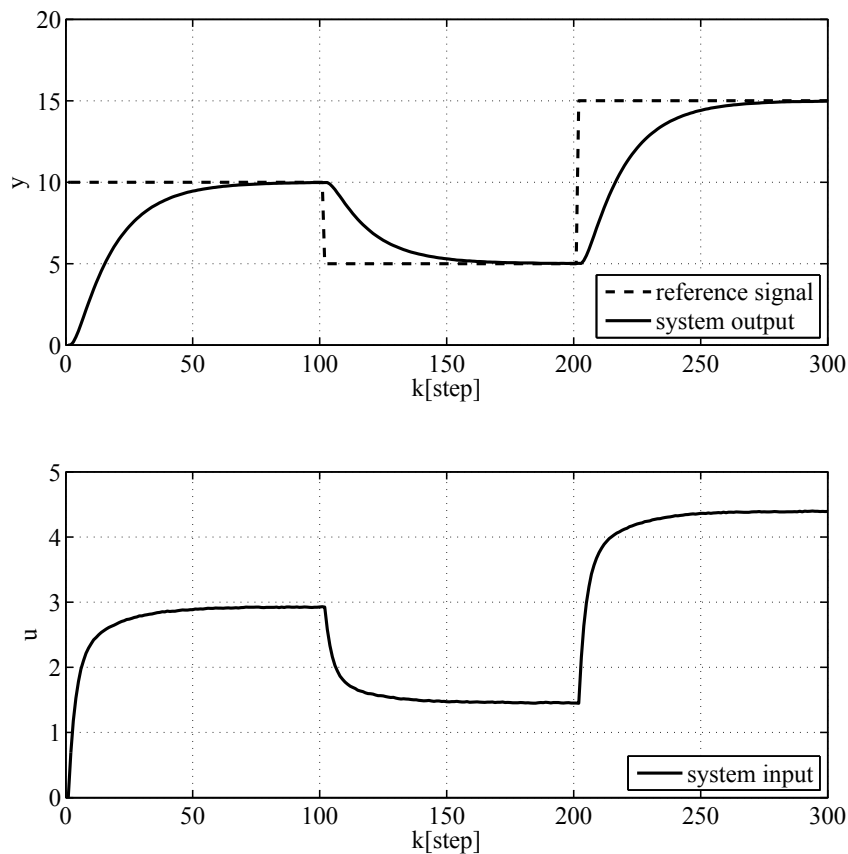

Fig. 2.4: The operating data (slow) when PID gains are $K_P = 1.00$, $K_I = 0.07$ and $K_D = 0.10$.

Furthermore, Fig. 2.7 shows the operating data when an on-off controller was applied the system, such as in the following equation:

$$u(k) = \begin{cases} 20.0 & (e(k) < 0) \\ 0.0 & (e(k) \geq 0) \end{cases} \quad (2.18)$$

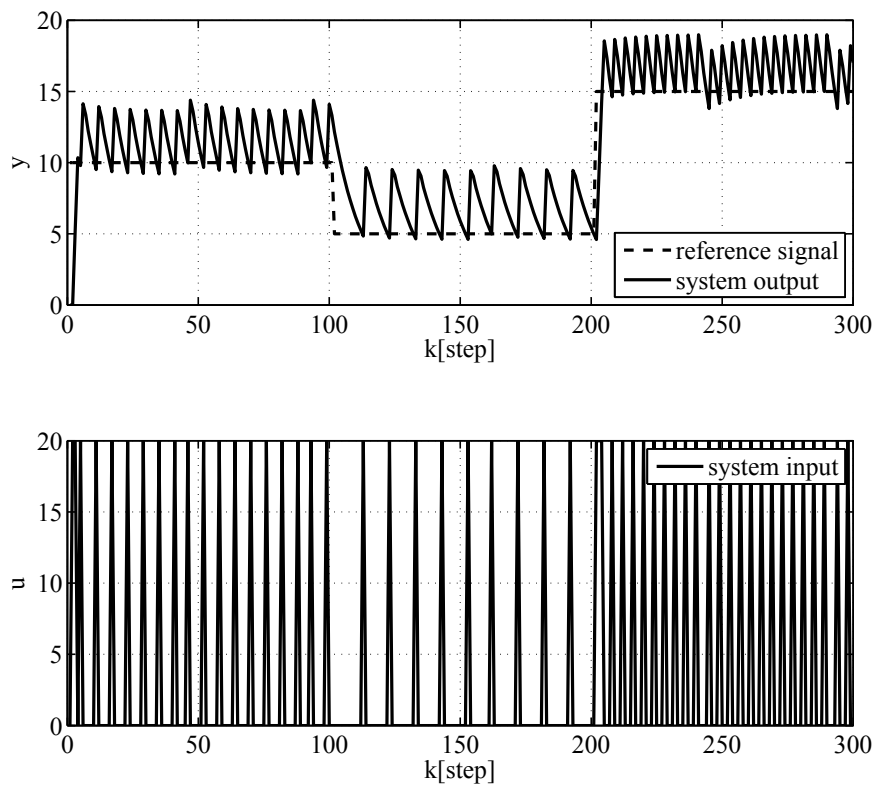

Fig. 2.5: The operating data when a on-off controller is employed

The genetic algorithm (GA)⁽⁵⁴⁻⁵⁶⁾ was used for optimization, and the fitness function is

$$f(p) := \frac{1}{1 + \frac{1}{N} \sum_{k=1}^N \left\{ G_m(z^{-1})\Phi(k) - y(k) \right\}^2}. \quad (2.19)$$

where N denotes the step of the operating data. The elements of the gene are given by each PID gains; then, elite selection, crossover and mutation operations are performed. When the

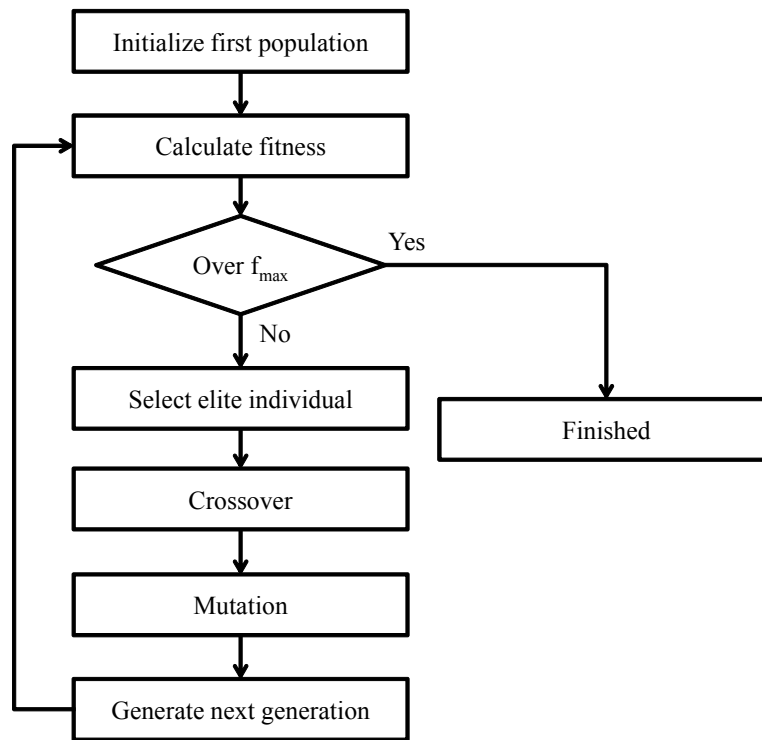

Fig. 2.6: The flow chart of GA.

Table 2.2: The user-specified parameters of proposed scheme for Example 1

population size	$m = 1000$
select rate	60%
crossover rate	40%
mutation rate	5%
end condition	$f_{\max} = 0.9$

evaluated value exceeds f_{\max} , the evolutionary computation is ended, and the gene is applied as an optimized PID gains.

Fig. 2.5 shows the control results of the proposed scheme using on-off controlled operating data. The computed PID gains were

$$K_P = 1.060, K_I = 0.217, K_D = 0.095. \quad (2.20)$$

Clearly, the proposed scheme was able to obtain the desired control performance even if the

output of the operating data did not eventually converge to the reference signal.

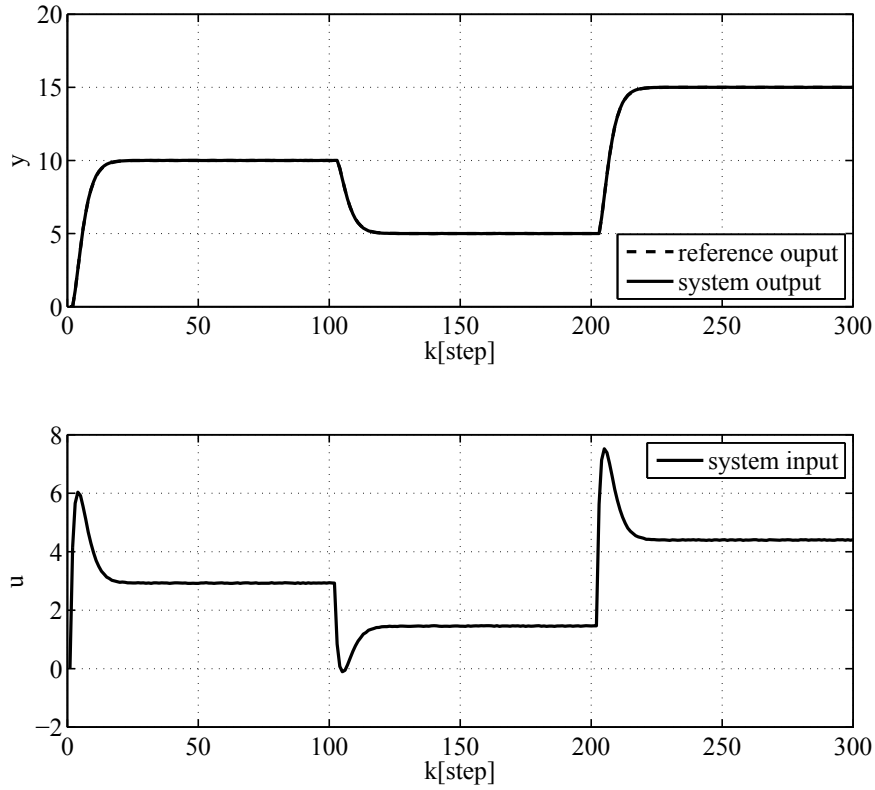

Fig. 2.7: The Control results using the result by the on-off controller.

The scheme was also used to simulate the system when the parameters of the reference model were changed in equation (2.10).

First, σ was considered. Figs. 2.8 and 2.9 show the control results by the proposed scheme for $\sigma = 3.0$ [s] and $\sigma = 5.0$ [s], respectively. Table 2.3 shows the obtained PID gains at each σ . Each system output changed with each σ , and each integral gain clearly changed significantly the rise time was increased.

Moreover, $P(z^{-1})$ shows in equation (2.21) and equation (2.22), respectively, when the σ sets to $\sigma = 3.0$ [s] and $\sigma = 10.0$ [s].

$$P(z^{-1}) = 1 - 1.03z^{-1} + 0.26z^{-2} \quad (2.21)$$

$$P(z^{-1}) = 1 - 1.64z^{-1} + 0.67z^{-2} \quad (2.22)$$

Table 2.3: PID parameters corresponding to the different σ .

σ	K_P	K_I	K_D
3.0	0.992	0.426	0.047
5.0	0.994	0.270	0.034
10.0	0.995	0.131	0.059

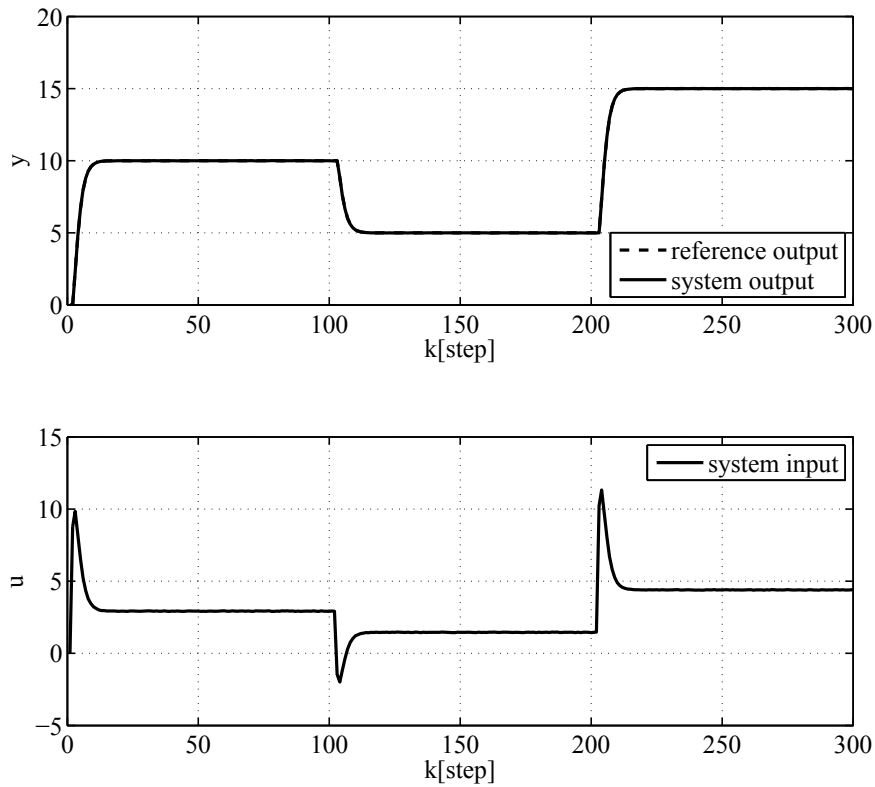
Fig. 2.8: The control result by using proposed scheme when $\sigma = 3.0$ [s].

Next, δ was considered. The following equations show when δ of the reference model was changed to $\delta = 0.5$, $\delta = 1.0$ and $\delta = 2.0$, respectively. In all cases, the other user-specified parameters were the same ($\sigma = 3$ [s]).

$$P(z^{-1}) = 1 - 1.23z^{-1} + 0.42z^{-2} \quad (2.23)$$

$$P(z^{-1}) = 1 - 1.36z^{-1} + 0.52z^{-2} \quad (2.24)$$

$$P(z^{-1}) = 1 - 1.53z^{-1} + 0.65z^{-2} \quad (2.25)$$

The proposed scheme, which is given by each $P(z^{-1})$, was employed to Example 1; The PID gains corresponding to $P(z^{-1})$ are shown in Table 2.4.

Table 2.4: PID parameters corresponding to different δ .

δ	K_P	K_I	K_D
0	0.992	0.426	0.447
0.5	0.921	0.421	0.468
1.0	0.531	0.597	0.523
2.0	0.035	0.437	0.587

Figs. 2.10, 2.11 and 2.12 show the control results.

For these results, the system output tracked the reference model output corresponding to the model. When δ was larger, the output waveform was damped. Therefore, if the operator desires faster response at the risk of tracking, δ of the reference model should be increased.

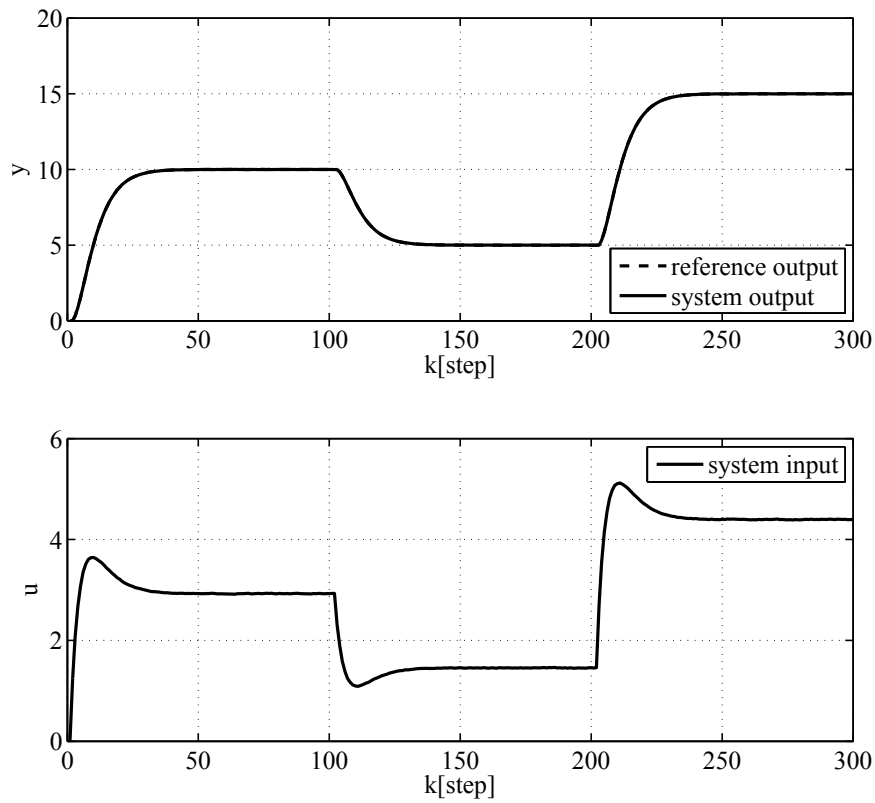

Fig. 2.9: The control result by using proposed scheme when $\sigma = 10.0$ [s].

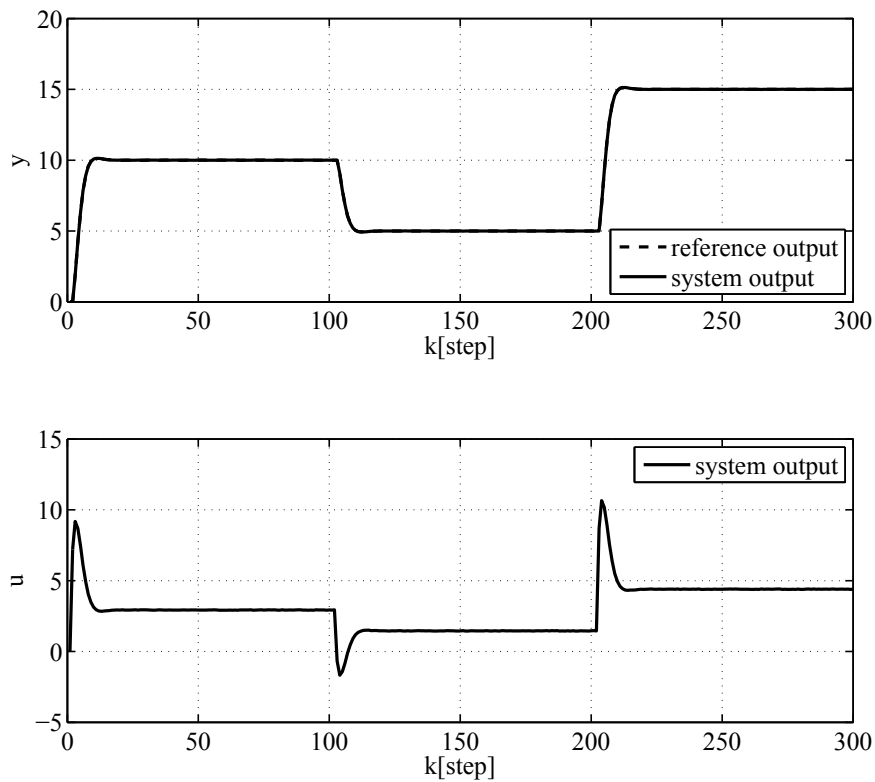

Fig. 2.10: The control result by using proposed scheme when $\delta = 0.5$ [s].

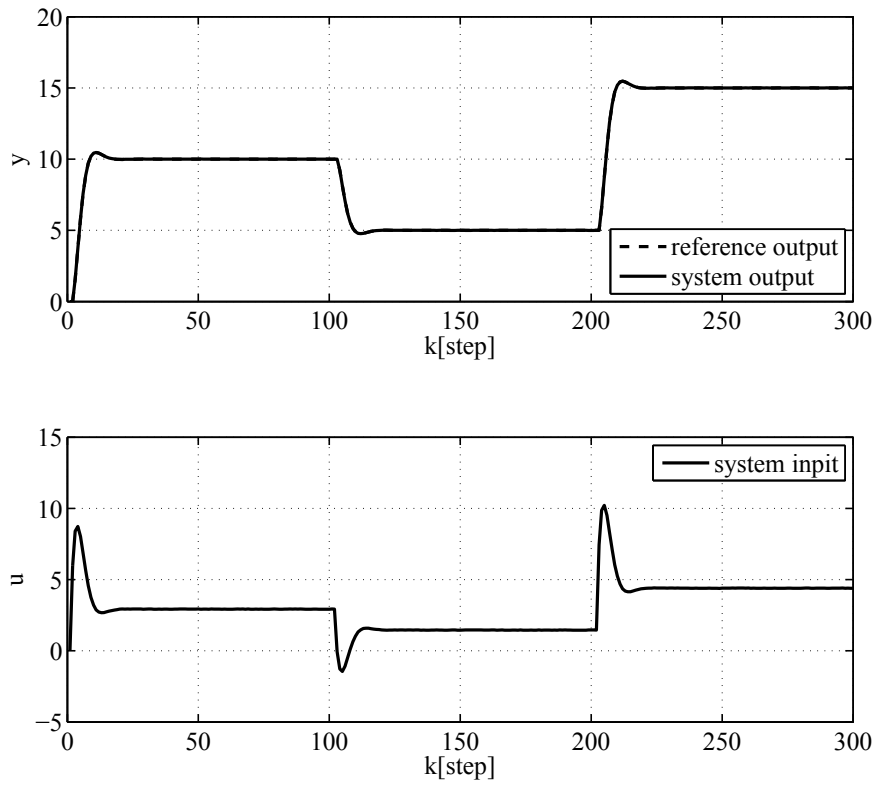

Fig. 2.11: The control result by using proposed scheme when $\delta = 1.0$ [s].

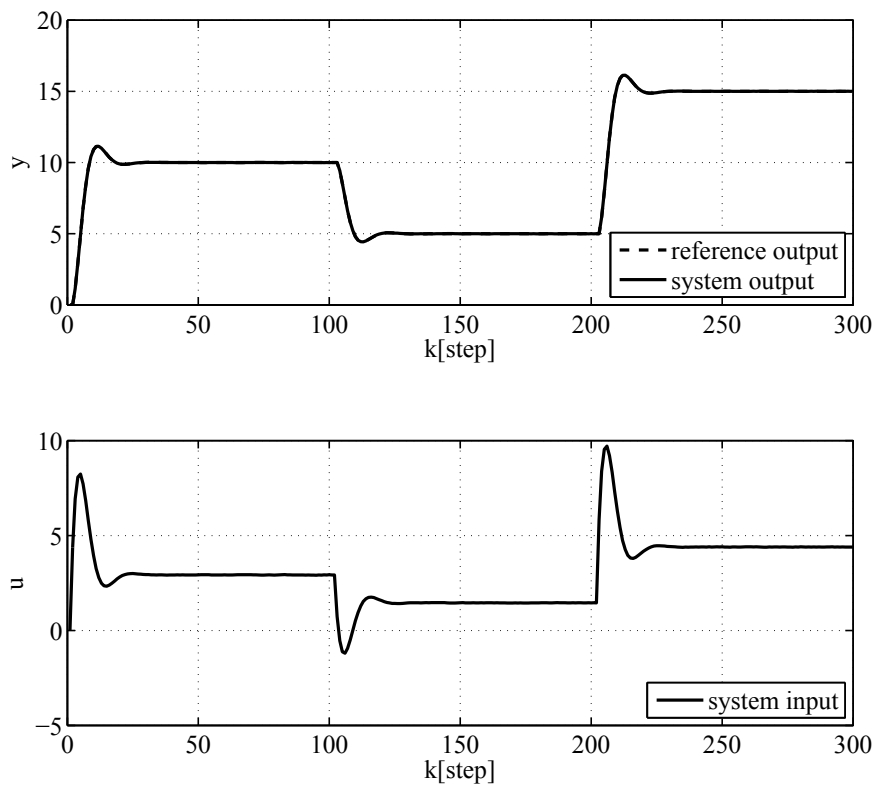

Fig. 2.12: The control result by using proposed scheme when $\delta = 2.0$ [s].

2.3.2 High-order lag system

Next, the effectiveness of the proposed scheme for a high-order system⁽¹⁾ was considered. The fourth-order continuous-time system was used.

$$G(s) = \frac{12s + 8}{20s^4 + 113s^3 + 147s^2 + 62s + 8} \quad (2.26)$$

In the following equation, the system in equation (2.26) was discretized with the sampling interval of $T_s = 1.0$ [s].

$$\begin{aligned} y(k) = & 1.835y(k-1) - 1.088y(k-2) + 0.211y(k-3) - 0.004y(k-4) \\ & + 0.211u(k-1) + 0.036u(k-2) - 0.024u(k-3) - 0.002u(k-4) \\ & + \xi(k) \end{aligned} \quad (2.27)$$

where $\xi(k)$ denotes a Gaussian white noise with a zero mean and a variance of 0.01^2 .

First, a PID control scheme with PID gains of $K_P = 1.0$, $K_I = 0.2$ and $K_D = 0.5$ was applied, where the reference signal is given by the following equation:

$$r(k) = \begin{cases} 5.0 & (0 < k \leq 100) \\ 15.0 & (100 < k \leq 200) \\ 10.0 & (200 < k \leq 300). \end{cases} \quad (2.28)$$

Fig. 2.13 shows the control result with oscillated because of the high-order lag element.

In contrast, the proposed scheme was used to calculate the PID gains based on the operating data. The reference model was designed by according to the user-specified parameters, where $\sigma = 5.0$ [s] and $\delta = 0.0$, and the following $P(z^{-1})$ was obtained.

$$P(z^{-1}) = 1 - 1.34z^{-1} + 0.45z^{-2} \quad (2.29)$$

Fig. 2.14 shows the control results by the proposed scheme. The obtained PID gains were $K_P = 1.756$, $K_I = 0.388$ and $K_D = 2.354$. Good control performance can clearly be obtained by using the proposed scheme.

In order to verify the effectiveness of a proposed scheme, the conventional scheme^(57,58) was applied to this system. The conventional scheme was a model-based PID control scheme where

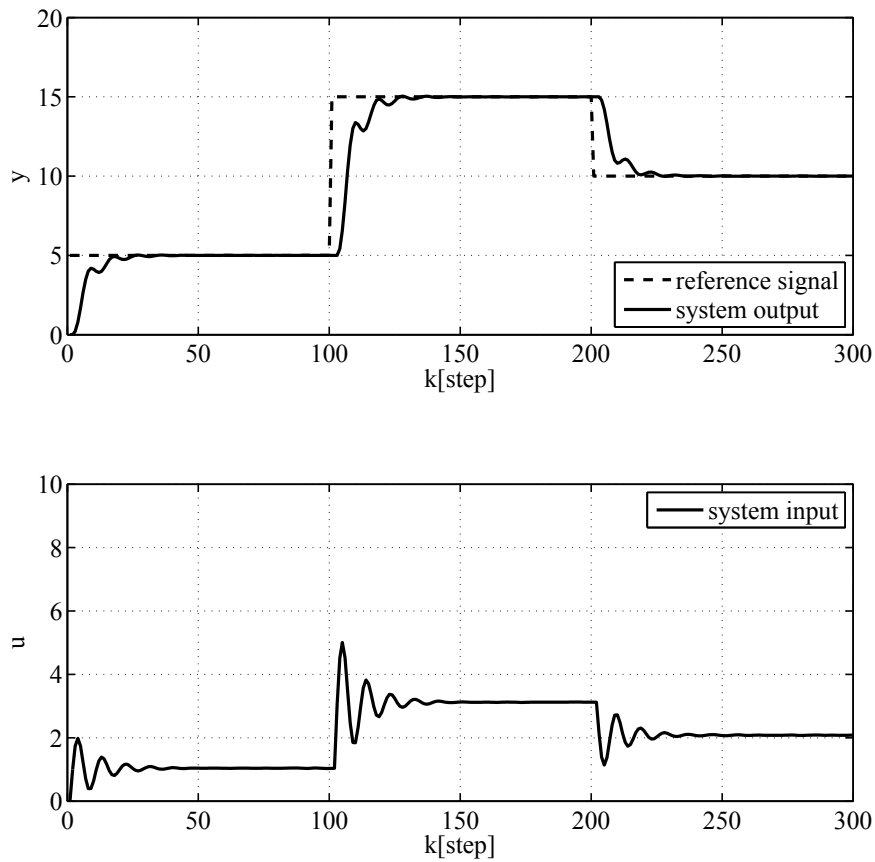

Fig. 2.13: Simulation result by using PID gains are determined by $K_P = 1.0$, $K_I = 1.0$ and $K_D = 0.5$.

the PID gains are estimated by a genetic algorithm(GA). This time, the following cases were considered.

- The model is correctly identified (model error of 0%)
- The model has 10% modeling error for the system gain.
- The model has 20% modeling error for the system gain.
- The model has 50% modeling error for the system gain.

For each of the above cases, the PID controller was designed using the computed PID gains. The PID gains are shown in Table 2.5.

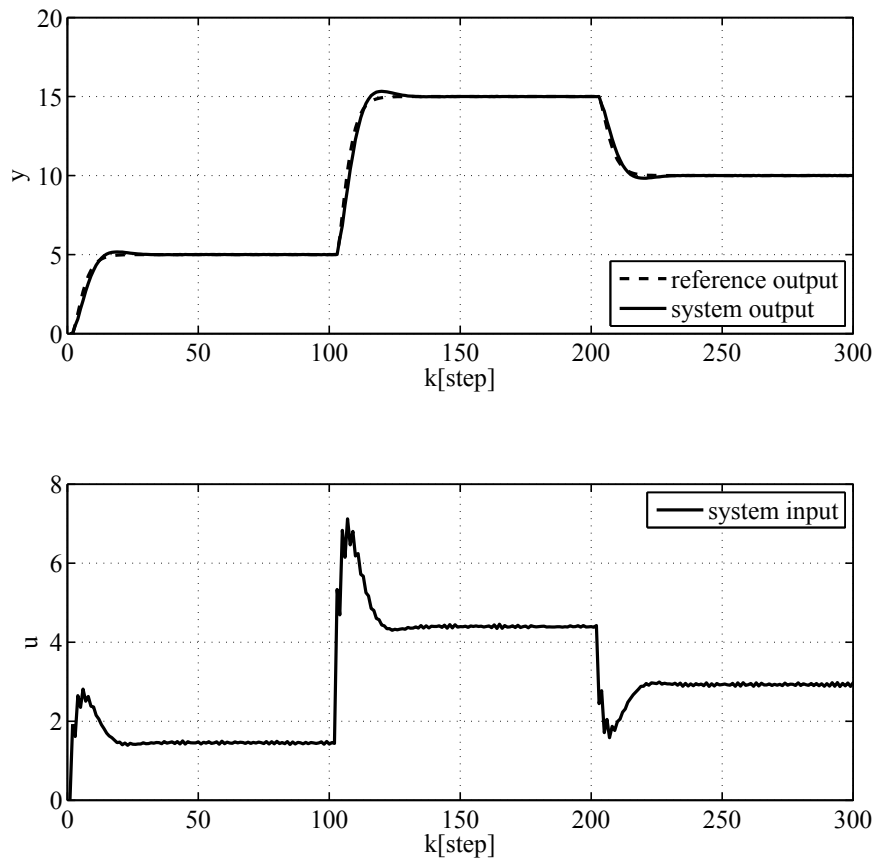

Fig. 2.14: Simulation result by using the proposed scheme PID gains are determined by $K_P = 1.756$, $K_I = 0.388$ and $K_D = 1.354$.

Table 2.5: PID parameters corresponding to the different model error by the conventional scheme.

modeling error rate	K_P	K_I	K_D
0%	0.087	0.021	0.075
10%	0.094	0.023	0.062
20%	0.108	0.026	0.094
50%	0.174	0.142	0.148

Figs. 2.15 and 2.16 show that, if PID gains with good response performance can be obtained if the model has been identified correctly. If not, the PID gains need to be adjusted. In contrast, the proposed scheme can obtain the desired response in just one iteration.

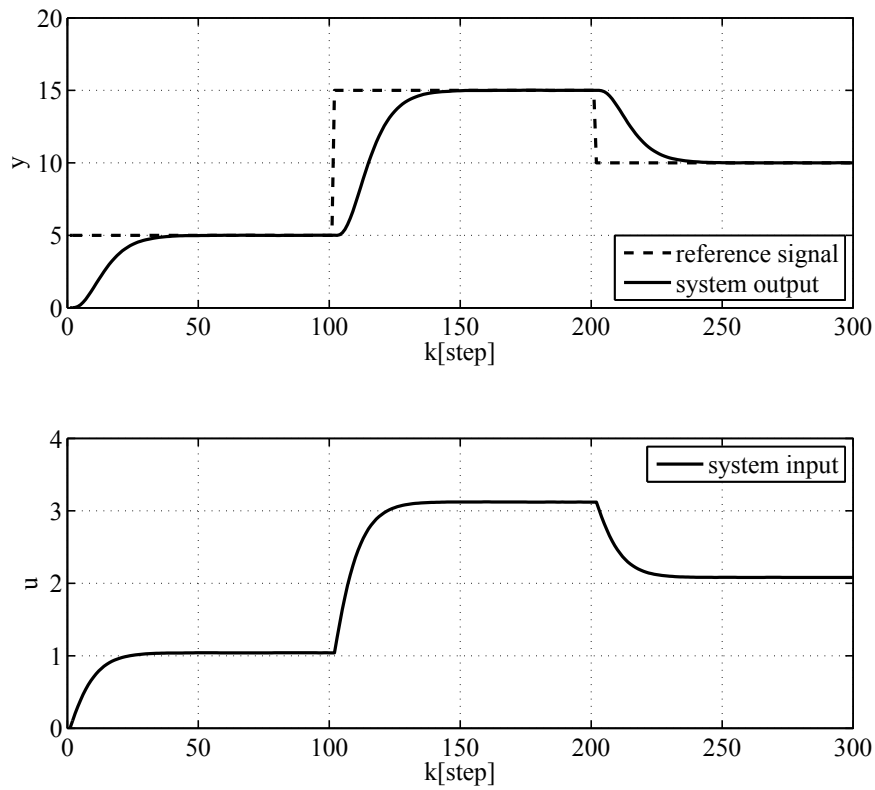

Fig. 2.15: The control result by using the conventional scheme when the model is correct.

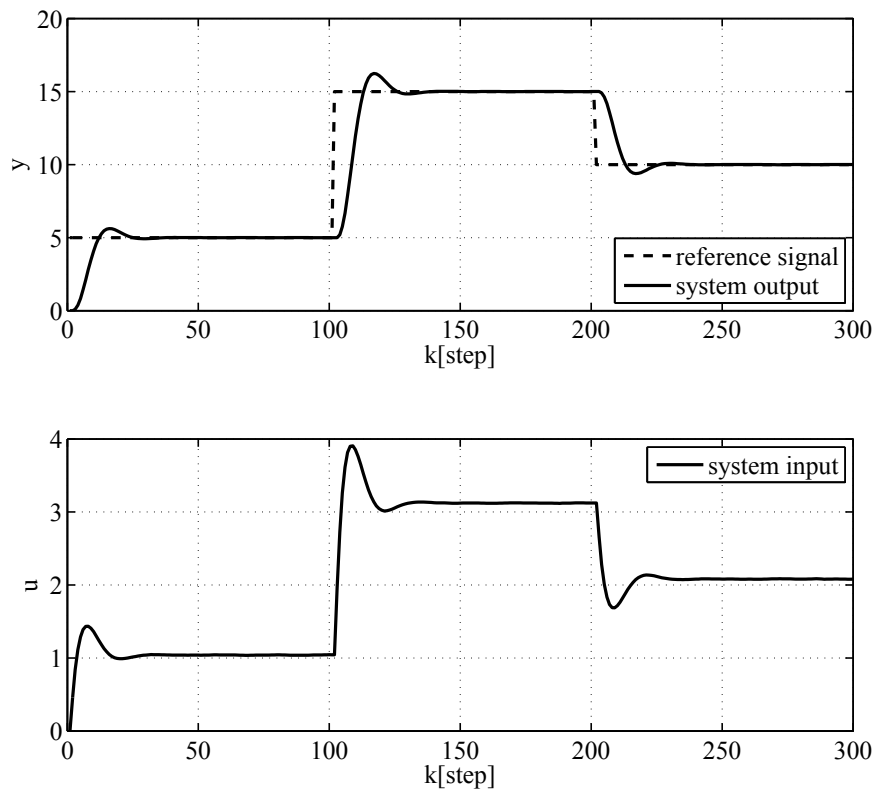

Fig. 2.16: The control result by using the conventional scheme when the model has 50% error.

2.3.3 Time delay system

Finally, a time delay system was considered because most process systems have a time delay. In general, a system with an L/T of over 0.5 is difficult to control.

The following equation was obtained by rewriting equation (2.13) for expansion to a time delay system.

$$J = \frac{1}{N} \sum_{k=1}^N \left\{ G_m(z^{-1})\Phi(k-d) - y(k) \right\}^2 \quad (2.30)$$

d denotes a time delay. Because the time delay is unknown in many cases, d is estimated at the same time as when the PID gains are computed. The steps to estimate d are as follows:

1. Each time d is changed, PID gains are calculated using equation (2.30).
2. d the smallest error is selected, and where d denotes the time delay of the system.
3. The proposed scheme employs the PID gain at that time.

The system uses as following equation⁽⁵⁹⁾.

$$G(s) = \frac{1}{s^3 + 2s^2 + 6s + 2} e^{-4s} \quad (2.31)$$

When the system is discretized with $T_s = 1.0$ [s], the following equation is given.

$$\begin{aligned} y(k) = & 0.187y(k-1) + 0.151y(k-2) + 0.135y(k-3) \\ & + 0.083u(k-d-1) + 0.152u(k-d-2) + 0.0289u(k-d-3) + \xi(k) \end{aligned} \quad (2.32)$$

where the time delay is $d = 4$. The following PID gains were determined by the Chien, Hrones & Reswick method (CHR) method⁽¹¹⁾ and applied as follows:

$$K_P = 1.5, K_I = 0.3, K_D = 3.0. \quad (2.33)$$

When the reference signal is given as:

$$r(k) = \begin{cases} 2.0 & (0 < k \leq 100) \\ 3.0 & (100 < k \leq 200) \\ 4.0 & (200 < k \leq 300). \end{cases} \quad (2.34)$$

The control result is as shown in Fig. 2.17. The reference model is given by $\sigma = 6.0$ [s] and $\delta = 0.0$, and $P(z^{-1})$ is designed with the following equation.

$$P(z^{-1}) = 1 - 1.43z^{-1} + 0.51z^{-2} \quad (2.35)$$

Table 2.6 shows the set of PID gains and the error when time delay was changed from 1 to 10. According to Table 2.6, the error was smallest at $d = 4$; this is the true time delay. Fig. 2.18 shows the control result when good performance was obtained. Therefore, the time

Table 2.6: PID gains and the error corresponding to each time delay.

d	K_P	K_I	K_D	generalized output error
1	4.065	0.753	10.000	0.350
2	2.492	0.496	6.083	0.236
3	1.647	0.362	3.516	0.027
4	1.152	0.286	1.729	0.019
5	0.851	0.241	0.429	0.030
6	0.781	0.227	0.301	0.052
7	0.698	0.218	0.001	0.152
8	0.554	0.185	0.001	0.821
9	0.506	0.162	0.001	2.021
10	0.524	0.144	0.001	3.587

delay can be estimated and whose system is controlled with the following control system: The desired control performance can be obtained by using the generalized output error even if the time delay of the system is unknown.

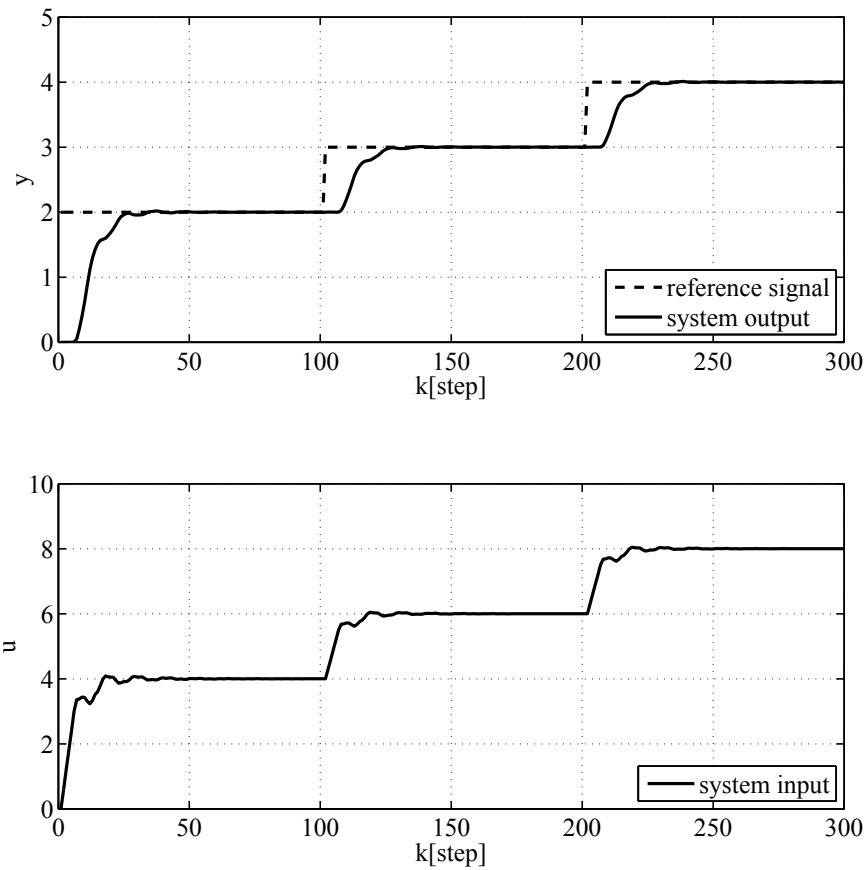

Fig. 2.17: The control result when $K_P = 1.5$, $K_I = 0.3$, $K_D = 3.0$ for a time delay system

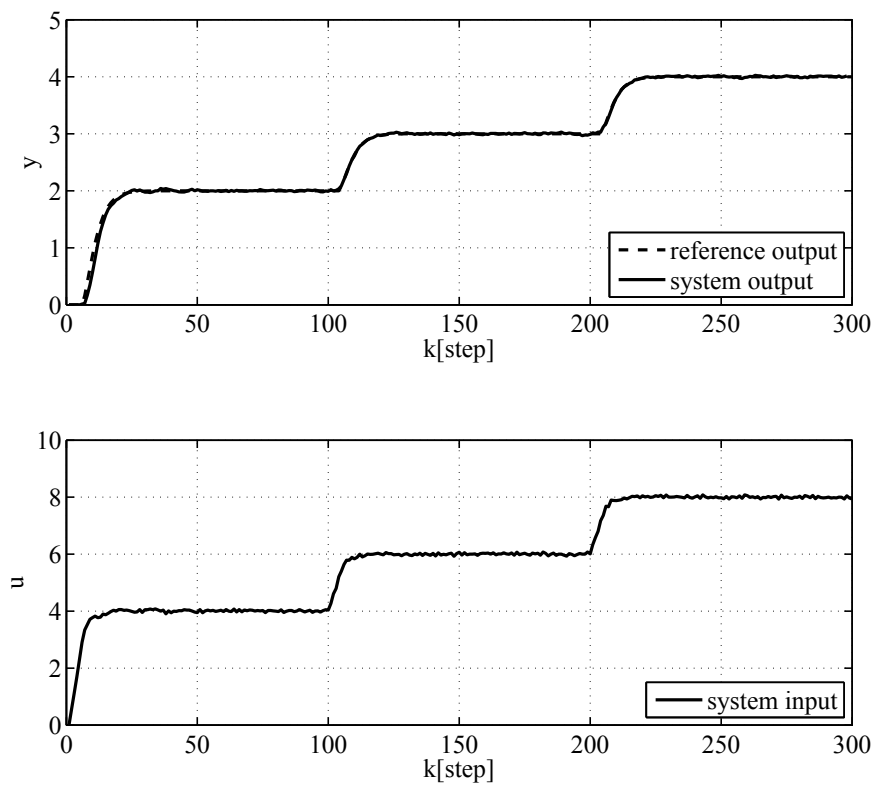

Fig. 2.18: The control result by the proposed scheme for a time delay system

2.4 Application for an injection molding system

2.4.1 About an injection molding system

The proposed method was experimentally evaluated by application to the heaters of an injection molding process⁽⁶⁰⁾. Fig. 2.19 shows the schematic figure of the system, and Fig. 2.20 shows a photograph. The injection molding process is one of the thermal processes used in plastic processing.

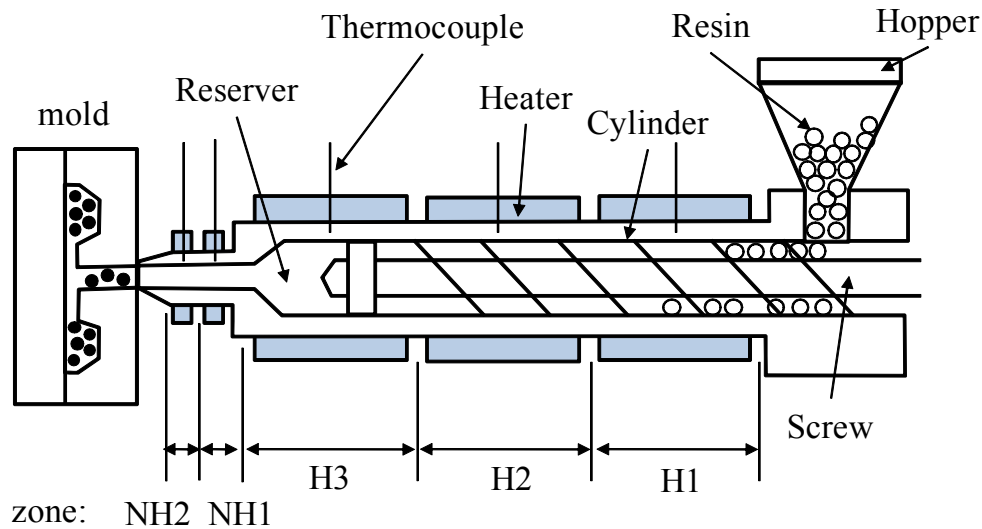

Fig. 2.19: Schematic figure of an injection molding machine

The following procedure is used in plastic processing.

1. Pellets(resin) are turned on the hopper.
2. The pellets are pushed out by the screw and gradually heated in each cylinder.
3. They finally fill the pushing type and are molded.

The control objective was to track the temperature of heater y to the desired temperature r . If the temperature is too high, molding is difficult because the pellets melt into a sticky mess.

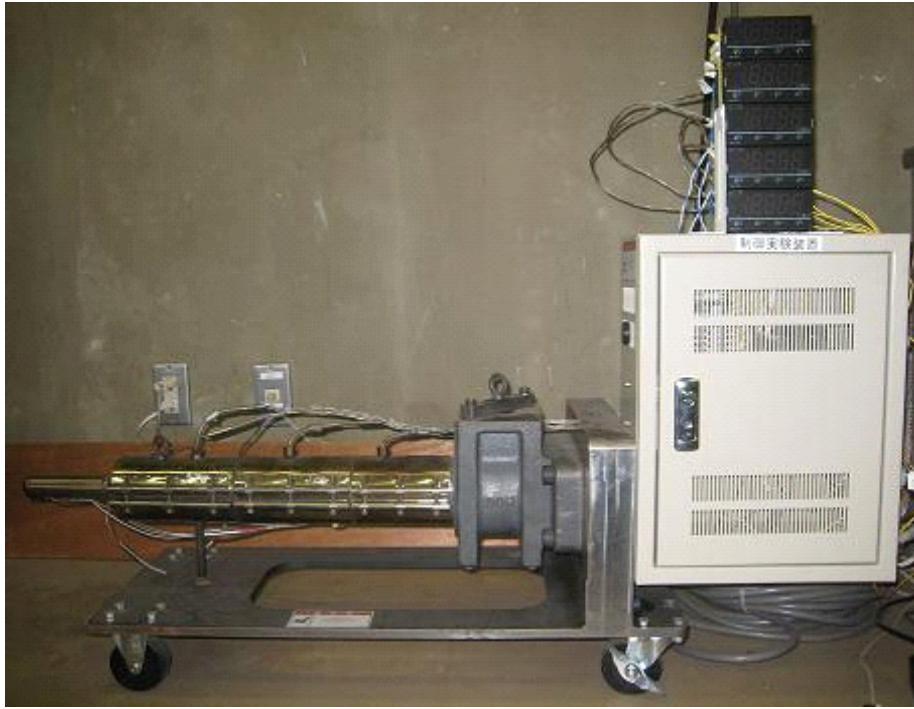

Fig. 2.20: The injection molding machine

If the temperature is too low, the pellets are insoluble and can not be molded. Therefore, the temperature in the cylinder must be properly adjusted.

The cylinder comprised four parts: H1, H2, H3 and NH. In addition, the nozzle heater (NH) was divided into sections of NH2, and NH1 from the tip. The controllers were independent of each other, and each heater was controlled with respect to each of the five parts (NH1, NH2, H1, H2, and H3). The sampling interval was $T_s = 3.0$ [s]. Only the control results for NH2 and H2 are presented in this paper. In these experiments, the PI controllers were designed for the dead time to be smaller than the time constant.

2.4.2 Control results

First, the PI control scheme was applied for NH2, which had the smallest thermal capacity. The reference signal is given by $r(k) = 125$, and the following gains were applied,

$$K_P = 10.0, K_I = 1.5. \quad (2.36)$$

Fig. 2.21 shows the control result.

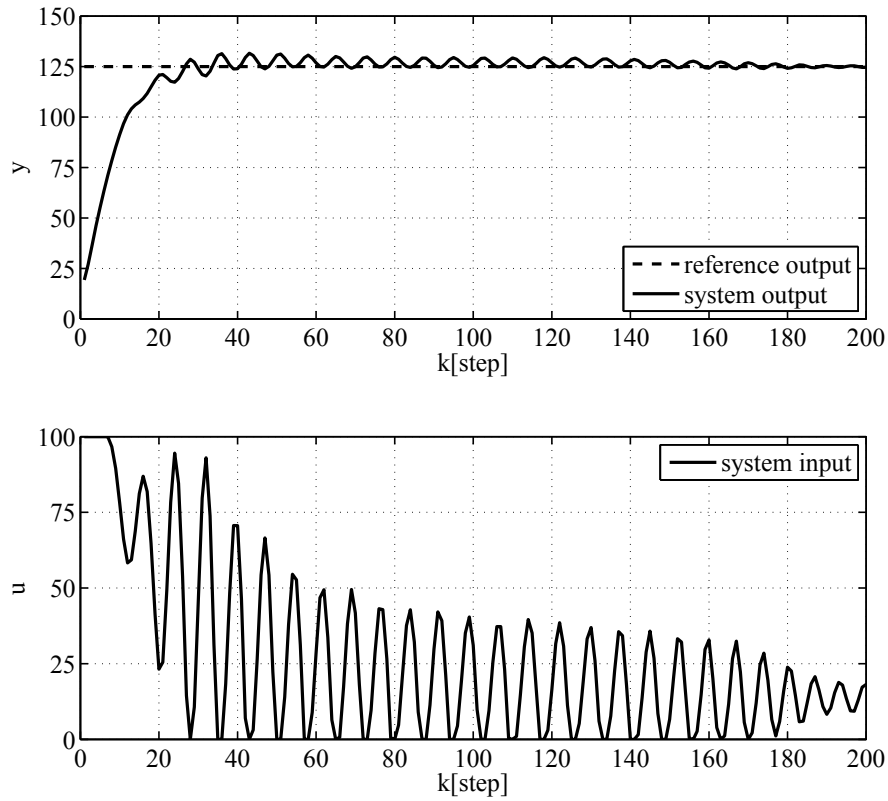

Fig. 2.21: Control result by employing the initial PI controller for NH2.

Next, the proposed scheme was applied when $P(z^{-1})$ was designed as follows:

$$P(z^{-1}) = 1 - 1.64z^{-1} + 0.67z^{-2}, \quad (2.37)$$

where each parameter was set with $\sigma = 30.0$ [s] and $\delta = 0.0$. Fig. 2.22 shows the control result using the proposed scheme, and the calculated PI gains were calculated using the following equation:

$$K_P = 4.909, \quad K_I = 0.452. \quad (2.38)$$

Fig. 2.22, verifies that the system output y tracked the reference output y_m without overshooting.

H2 was then considered. The initial PI gains were as follows:

$$K_P = 5.0, \quad K_I = 0.8. \quad (2.39)$$

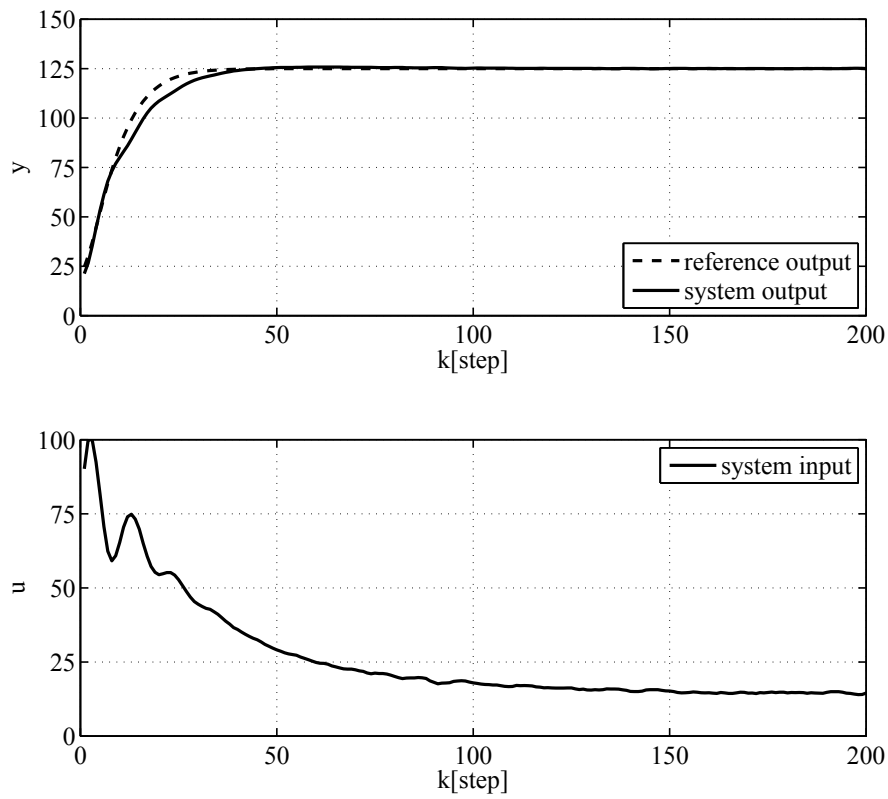

Fig. 2.22: Control result by employed the proposed scheme for NH2.

Fig. 2.23 shows the control result. H2 had the largest thermal capacity.

Because the proposed scheme was applied, the control result was used as the operating data. $P(z^{-1})$ was designed using the following equation:

$$P(z^{-1}) = 1 - 1.95z^{-1} + 0.95z^{-2}. \quad (2.40)$$

The parameters of $P(z^{-1})$ were set to $\sigma = 250$ [s] and $\delta = 0.0$. The control result is shown in Fig. 2.24. The computed PI gains were as follows:

$$K_P = 5.126, \quad K_I = 0.059. \quad (2.41)$$

The results showed that, the system output y was improved and the system input u was not oscillatory when the proposed scheme was applied.

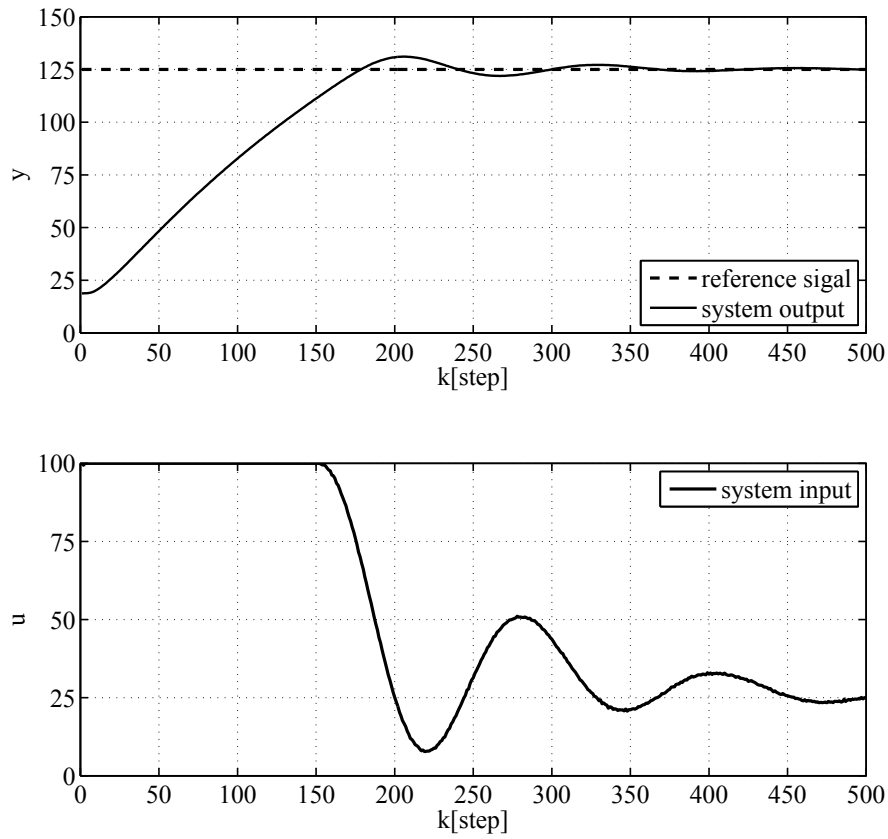

Fig. 2.23: Control result by employed the initial PI controller for H2.

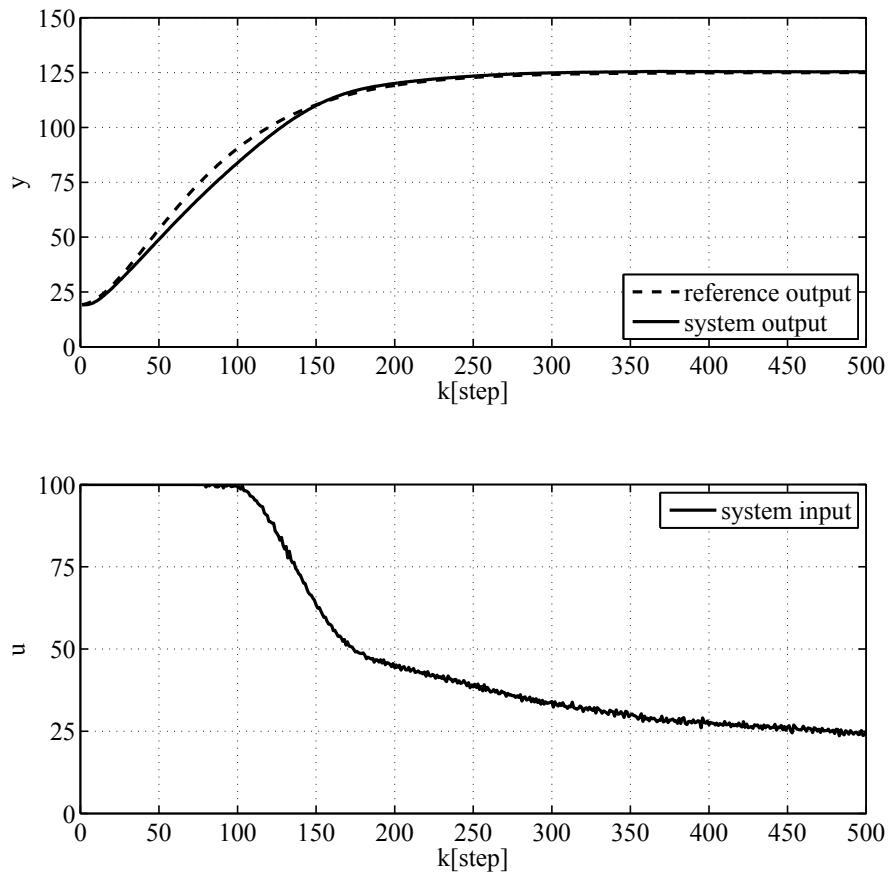

Fig. 2.24: Control result by employed the proposed scheme for H2.

2.5 Conclusions

The chapter has presented data-oriented PID control scheme for a single-input/single-output linear system. When designing a PID controller, identifying the system properties and adjusting PID gains are difficult. Thus, the proposed PID control system adjusts the control parameters (PID gain) so that the generalized output is equivalent to the system output of the operating.

Section 2.2 has presented the proposed control system. In the proposed scheme, the generalized output is defined from a discretized the discrete-time PID controller. PID gains included in the generalized output are optimized to reduce generalized output error using the previously obtained operating data.

Section 2.3, has compared the proposed scheme with a conventional scheme using some numerical examples. The effectiveness of the proposed scheme has been numerically verified. In results, the conventional scheme has performed well if the system model was known. However, the output has been wrong if it was not known. The scheme is attributed to the accuracy of the obtained model. In a the conventional model-based design scheme, a large model error, is reflected in the calculated PID gains. In contract, the proposed scheme does not require a description model and can calculate workable PID gains. The desired output can be obtained simply with the operating data and design specification. The PID gains do not depend on the operating data. The proposed scheme can use operating data even when the system output does not converge to the reference signal.

For a time delay system, the desired control result can be obtained because the time delay is estimated at the same time as when the computing PID gains are computed.

Section 2.4 has verified the usefulness of this scheme by presenting its application to an injection molding process. In this experiment, heaters with large and small thermal capacities have been evaluated. The experimental results have demonstrated the effectiveness of the proposed scheme since the both heaters have showed good control performance.

Chapter 3

Design of a PID controller for multivariable systems

3.1 Introduction

In a step toward the practical application of the proposed method, this chapter discusses its extension to multi-input/multi-output linear system.

Chapter 2 presents a proposed design scheme for PID controllers. Although the proposed scheme is applicable to single-input/single-output systems, most real systems are multivariate systems. Therefore, the scheme needs to be extended to multi-input/multi-output(MIMO) cases. In addition, the mutual interference between the input and output needs to be considered for MIMO systems. For multivariable systems with interference, control methods are usually based on modern control theory⁽⁶¹⁻⁶⁴⁾ or using pre-compensator^(65,66,78). Real systems mostly use a pre-compensator for decoupling. However, the system parameters need to be identified in order to design a pre-compensator. Therefore, the proposed scheme solves this problem by optimizing non-diagonal elements in the PID gain matrix.

In this chapter, the problem statement presents first. Next, the proposed scheme is explained in detail. The effectiveness of the proposed scheme is demonstrated through some numerical some simulation examples.

3.2 Design of a control system

3.2.1 The description of a system

Fig. 3.1 shows a control system with p -input and p -output.

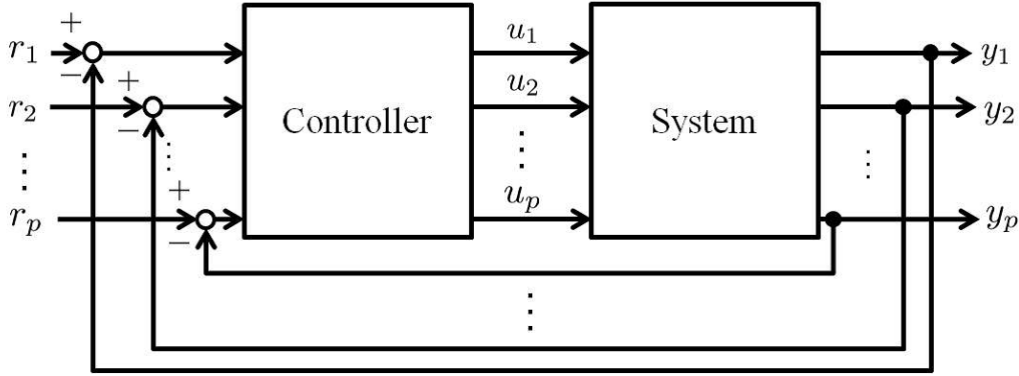

Fig. 3.1: Block diagram of multivariable system

The control law is given by the following equation:

$$\begin{aligned} \mathbf{u}(k) = & \mathbf{u}(k-1) + \mathbf{K}_P \{ \mathbf{y}(k-1) - \mathbf{y}(k) \} + \mathbf{K}_I \{ \mathbf{r}(k) - \mathbf{y}(k) \} \\ & + \mathbf{K}_D \{ 2\mathbf{y}(k-1) - \mathbf{y}(k-2) - \mathbf{y}(k) \}, \end{aligned} \quad (3.1)$$

where $\mathbf{u}(k)$, $\mathbf{y}(k)$ and $\mathbf{r}(k)$ denote the control input signal, corresponding output signal, and reference signal, respectively. These parameters are given by p -dim vectors, which are as follows:

$$\left. \begin{aligned} \mathbf{u}(k) &= [u_1(k), u_2(k), \dots, u_p(k)]^T \\ \mathbf{y}(k) &= [y_1(k), y_2(k), \dots, y_p(k)]^T \\ \mathbf{r}(k) &= [r_1(k), r_2(k), \dots, r_p(k)]^T. \end{aligned} \right\} \quad (3.2)$$

\mathbf{K}_P , \mathbf{K}_I , and \mathbf{K}_D are the proportional gain, integral gain and derivative gain matrices, respectively. Each matrix is $\mathbf{K}_P \in \mathbf{R}^{p \times p}$, $\mathbf{K}_I \in \mathbf{R}^{p \times p}$ and $\mathbf{K}_D \in \mathbf{R}^{p \times p}$. In addition, the mutual interference in a multivariable system is alleviated by the non-diagonal elements in each gain matrix.

3.2.2 Design of a controller

In the proposed scheme, the generalized output is developed from the PID control law of equation (3.1), and PID gain matrices are calculated so that the generalized output becomes

identical to the system output \mathbf{y} . The detail of the proposed scheme are explained below. In this scheme, the system has an output equal to the number of inputs because process systems are assumed.

First, equation (3.1) can be rewritten as follows:

$$\begin{aligned} \tilde{\mathbf{u}}(k) + (\mathbf{K}_P + \mathbf{K}_I + \mathbf{K}_D)\mathbf{y}(k) - (\mathbf{K}_P + 2\mathbf{K}_D)\mathbf{y}(k-1) \\ + \mathbf{K}_D\mathbf{y}(k-2) - \mathbf{K}_I\mathbf{r}(k) = 0 \end{aligned} \quad (3.3)$$

where $\tilde{\mathbf{u}}$ is given by the following equation:

$$\tilde{\mathbf{u}}(k) = [\Delta u_1(k) \ \Delta u_2(k) \ \cdots \ \Delta u_p(k)]^T. \quad (3.4)$$

Δ denotes the differencing operator and is defined as $\Delta := 1 - z^{-1}$. Second, \mathbf{K}_I is assumed so that $\det \mathbf{K}_I \neq 0$, and multiplying both sides of equation (3.3) by \mathbf{K}_I^{-1} gives the following equation.

$$\begin{aligned} \mathbf{K}_I^{-1}\tilde{\mathbf{u}}(k) + \mathbf{K}_I^{-1}(\mathbf{K}_P + \mathbf{K}_I + \mathbf{K}_D)\mathbf{y}(k) \\ - \mathbf{K}_I^{-1}(\mathbf{K}_P + 2\mathbf{K}_D)\mathbf{y}(k-1) + \mathbf{K}_I^{-1}\mathbf{K}_D\mathbf{y}(k-2) - \mathbf{r}(k) = 0 \end{aligned} \quad (3.5)$$

The generalized output $\Phi(k)$ is defined by the following equation:

$$\Phi(k) := \mathbf{C}_1\tilde{\mathbf{u}}(k) + \mathbf{C}_2\mathbf{y}(k) + \mathbf{C}_3\mathbf{y}(k-1) + (\mathbf{I} - \mathbf{C}_2 - \mathbf{C}_3)\mathbf{y}(k-2) \quad (3.6)$$

where

$$\Phi(k) = [\Phi_1(k), \Phi_2(k), \cdots, \Phi_p(k)]^T. \quad (3.7)$$

Here, $\mathbf{C}_i \in \mathbf{R}^{p \times p}$ ($i = 1, 2, 3$) are given by

$$\left. \begin{aligned} \mathbf{C}_1 &= \mathbf{K}_I^{-1} \\ \mathbf{C}_2 &= \mathbf{K}_I^{-1}(\mathbf{K}_P + \mathbf{K}_I + \mathbf{K}_D) \\ \mathbf{C}_3 &= -\mathbf{K}_I^{-1}(\mathbf{K}_P + 2\mathbf{K}_D). \end{aligned} \right\} \quad (3.8)$$

In this scheme, the system output $\mathbf{y}(k)$ tracks to the reference model output $\mathbf{y}_m(k)$ so that the characteristics of the closed loop are close to the characteristics of the reference model $\mathbf{G}_m(z^{-1})$. The reference model output \mathbf{y}_m is given by equation (3.9); the p -vector is shown in equation (3.10).

$$\mathbf{y}_m(k) = \mathbf{G}_m(z^{-1})\Phi(k) \quad (3.9)$$

$$\mathbf{y}_m(k) = [y_{r_1}(k), y_{r_2}(k), \dots, y_{r_p}(k)] \quad (3.10)$$

The reference model $\mathbf{G}_m(z^{-1})$ can be used with any characteristic polynomial. In this case, the following equations are introduced to design an output waveform for the rise-time according to two parameter⁽⁵³⁾:

$$\mathbf{G}_m(z^{-1}) = \text{diag}\{G_{m_1}(z^{-1}), G_{m_2}(z^{-1}), \dots, G_{m_p}(z^{-1})\} \quad (3.11)$$

$$G_{m_j}(z^{-1}) = \frac{z^{-1}P(1)}{P_j(z^{-1})} \quad (3.12)$$

$$P_j(z^{-1}) = 1 + p_{1_j}z^{-1} + p_{2_j}z^{-2} \quad (3.13)$$

where p_{1_j} and p_{2_j} ($j = 1, 2, \dots, p$) are determined⁽⁵³⁾ by

$$\left. \begin{aligned} p_{1_j} &= -2e^{-\frac{\rho_j}{2\mu_j}} \cos\left(\frac{\sqrt{4\mu_j-1}}{2\mu_j}\rho_j\right) \\ p_{2_j} &= e^{-\frac{\rho_j}{\mu_j}} \\ \rho_j &:= \frac{T_s}{\sigma_j} \\ \mu_j &:= 0.25(1 - \delta_j) + 0.51\delta_j. \end{aligned} \right\} \quad (3.14)$$

T_s denotes the sampling interval. σ_j related to to the rise time. Similarly, μ_j is the damping index and is adjusted by δ_j .

Therefore, to optimize the parameter matrix \mathbf{C}_i ($i = 1, 2, 3$) of the generalized output $\Phi(k)$, the following evaluated function J is used:

$$J = \sum_{j=1}^p \lambda_j \left\{ \sum_{k=1}^N \varepsilon_j^2(k) \right\} \quad (3.15)$$

$$\boldsymbol{\varepsilon}(k) = \mathbf{y}(k) - \mathbf{y}_m(k) \quad (3.16)$$

$$\boldsymbol{\varepsilon}(k) = [\varepsilon_1(k), \varepsilon_2(k), \dots, \varepsilon_p(k)]^T \quad (3.17)$$

where N is the step of the operating data and λ_j ($j = 1, 2, \dots, p$) is the weight parameter for each controller. Although each λ_j should be designed according to the operating conditions, $\lambda_j = 1$ in this paper for simplicity. \mathbf{C}_i ($i = 1, 2, 3$) is calculated by a suitable optimization algorithm to

be a regular matrix. In this paper, \mathbf{C}_i is adjusted by using 'fmincon' of Optimization Toolbox in Matlab.

If \mathbf{C}_i is calculated, the PID gain matrix can be obtained as follows:

$$\left. \begin{aligned} \mathbf{K}_P &= \mathbf{C}_1^{-1}(2\mathbf{C}_2 + \mathbf{C}_3 - 2\mathbf{I}) \\ \mathbf{K}_I &= \mathbf{C}_1^{-1} \\ \mathbf{K}_D &= \mathbf{C}_1^{-1}(\mathbf{I} - \mathbf{C}_2 - \mathbf{C}_3). \end{aligned} \right\} \quad (3.18)$$

Therefore, the control system is constructed using the obtained PID gain matrix.

The robustness of the proposed method strongly depends on the rise time in the reference model. Therefore, if the rise time is small for higher-order lag and time delay systems, calculating a PID gain matrix which ensures stability is difficult. This is also a problem because of the control of the three PID parameters. In the case of PID control systems, the rise time must be set to a relatively large value to obtain a stable control output. If the output is required to rise faster, the controller should not be restricted to a PID controller, and a high-order controller should be used.

3.3 Simulation Examples

3.3.1 Two-input/two-output system

In order to verify the effectiveness of the proposed scheme, some numerical examples were simulated. First, a two-input/two-output system, was considered and is represented by the following equation⁽⁶⁷⁾:

$$\begin{aligned} \mathbf{y}(k) &= \begin{bmatrix} 0.9 & 0 \\ 0 & 0.8 \end{bmatrix} \mathbf{y}(k-1) + \begin{bmatrix} 0.2 & 0 \\ 0 & 0.1 \end{bmatrix} \mathbf{y}(k-2) \\ &+ \begin{bmatrix} 0.6 & 0.5 \\ 0.4 & 0.8 \end{bmatrix} \mathbf{u}(k-1) + \begin{bmatrix} 0.3 & 0.4 \\ 0.3 & 0.3 \end{bmatrix} \mathbf{u}(k-2) + \boldsymbol{\xi}(k) \end{aligned} \quad (3.19)$$

where $\boldsymbol{\xi}(k)$ is given by the following equation.

$$\boldsymbol{\xi}(k) = \begin{bmatrix} \xi_1(k) & \xi_2(k) \end{bmatrix}^T \quad (3.20)$$

$\xi_j(k)$ ($j = 1, 2$) is a Gaussian white noise with a zero mean and variance of 0.01. Similarly, the reference signals are given as follows:

$$r_1(k) = \begin{cases} 1.0 & (0 \leq k \leq 200) \\ 2.0 & (200 < k \leq 400) \\ 0.5 & (400 < k \leq 600) \end{cases} \quad (3.21)$$

$$r_2(k) = \begin{cases} 3.0 & (0 \leq k \leq 250) \\ 1.0 & (250 < k \leq 450) \\ 2.0 & (450 < k \leq 600) \end{cases} \quad (3.22)$$

Next, the following PID gain matrix was applied, and the operating data shown in Fig. 3.2 were obtained. The following equation shows the diagonalized matrix of the PID gains by the Chien, Hrones & Reswick (CHR) method⁽¹¹⁾.

$$\mathbf{K}_P = \begin{bmatrix} 0.36 & 0 \\ 0 & 0.43 \end{bmatrix}, \mathbf{K}_I = \begin{bmatrix} 0.21 & 0 \\ 0 & 0.12 \end{bmatrix}, \mathbf{K}_D = \begin{bmatrix} 0.14 & 0 \\ 0 & 0.17 \end{bmatrix} \quad (3.23)$$

Fig. 3.2 shows that the outputs nearly converged to the reference signals, although y_1 shows an overshoot. However, the outputs were clearly greatly influenced by each other.

Next, the proposed method is applied using operating data on the control results in Fig. 3.2. The reference model was designed by setting $T_s = 1.0[\text{s}]$, $\sigma_1 = 3.0[\text{s}]$, $\sigma_2 = 6.0[\text{s}]$, and $\delta_1 = \delta_2 = 0.0$. The following polynomial was obtained:

$$G_{m_1}(z^{-1}) = \frac{0.24z^{-1}}{1 - 1.03z^{-1} + 0.26z^{-2}} \quad (3.24)$$

$$G_{m_2}(z^{-1}) = \frac{0.08z^{-1}}{1 - 1.43z^{-1} + 0.51z^{-2}}. \quad (3.25)$$

The weight parameter λ_j to each output is $\lambda_1 = \lambda_2 = 1.00$.

Fig. 3.3 shows the control result; the computed PID gain matrix was

$$\mathbf{K}_P = \begin{bmatrix} 0.20 & 0.68 \\ -0.29 & 0.04 \end{bmatrix}, \mathbf{K}_I = \begin{bmatrix} 0.70 & -0.38 \\ -0.64 & 0.50 \end{bmatrix}, \mathbf{K}_D = \begin{bmatrix} 1.21 & -2.44 \\ -0.89 & 1.26 \end{bmatrix} \quad (3.26)$$

A comparison of these results, clearly shows that the proposed scheme can be decoupled about y_1 effectively.

Next, the relationship between the calculated PID gain matrix and operating data was verified. The proposed scheme was applied with the following PID gain matrix using the obtained operating data. Fig. 3.4 shows the control results of the operating data; they converged to the reference value while oscillating.

$$\mathbf{K}_P = \begin{bmatrix} 0.24 & 0 \\ 0 & 0.43 \end{bmatrix}, \mathbf{K}_I = \begin{bmatrix} 0.10 & 0 \\ 0 & 0.12 \end{bmatrix}, \mathbf{K}_D = \begin{bmatrix} 0.09 & 0 \\ 0 & 0.17 \end{bmatrix} \quad (3.27)$$

The PID gains matrix was computed using the following equation:

$$\mathbf{K}_P = \begin{bmatrix} 0.47 & 0.66 \\ -0.31 & 0.07 \end{bmatrix}, \mathbf{K}_I = \begin{bmatrix} 0.88 & -0.26 \\ -0.70 & 0.45 \end{bmatrix}, \mathbf{K}_D = \begin{bmatrix} 1.43 & 2.14 \\ -0.70 & 1.36 \end{bmatrix} \quad (3.28)$$

Comparing equations (3.26) and (3.28) equivalent PID gain matrix was obtained.

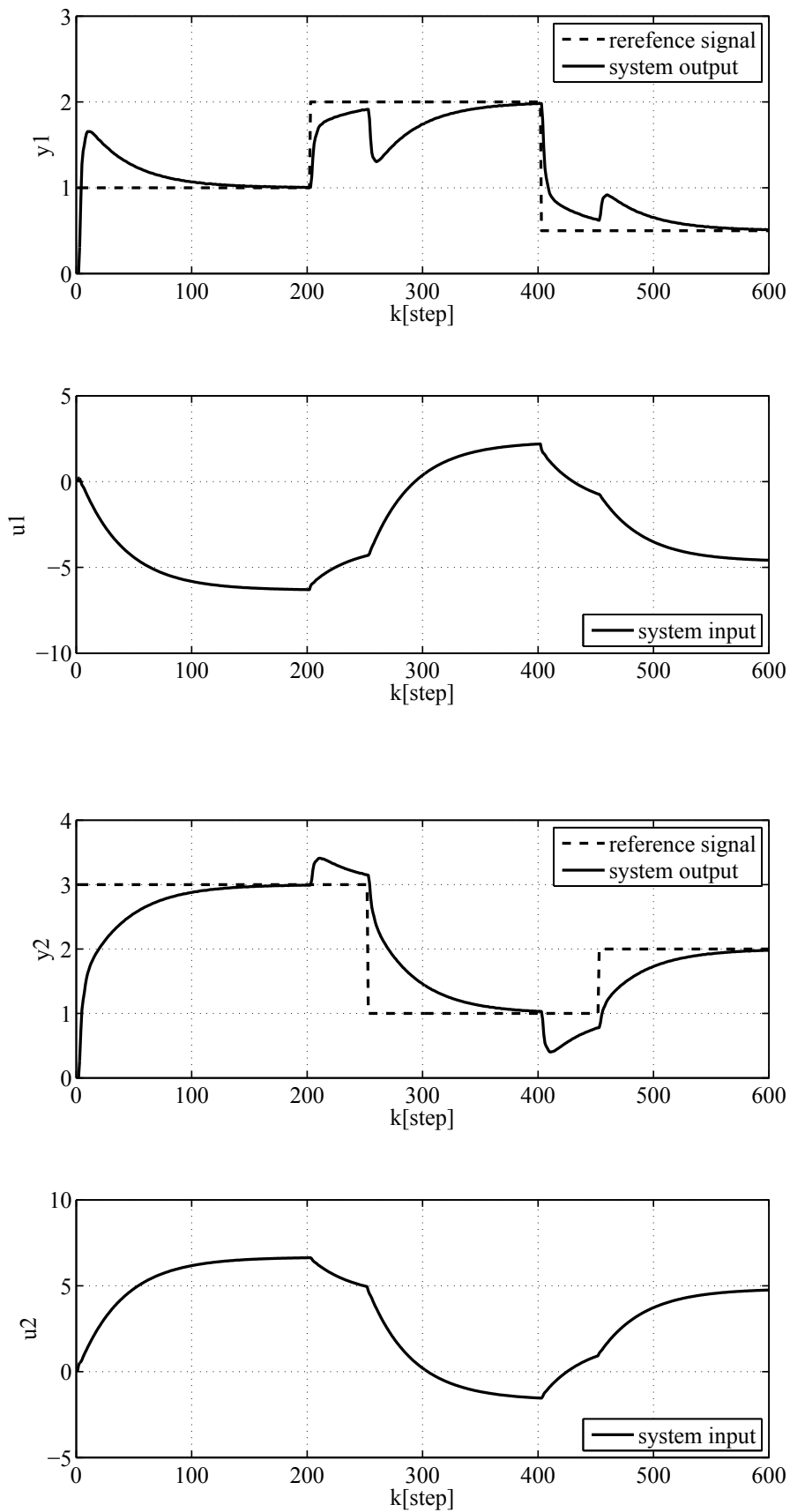

Fig. 3.2: Control result by using CHR method for Example 1.

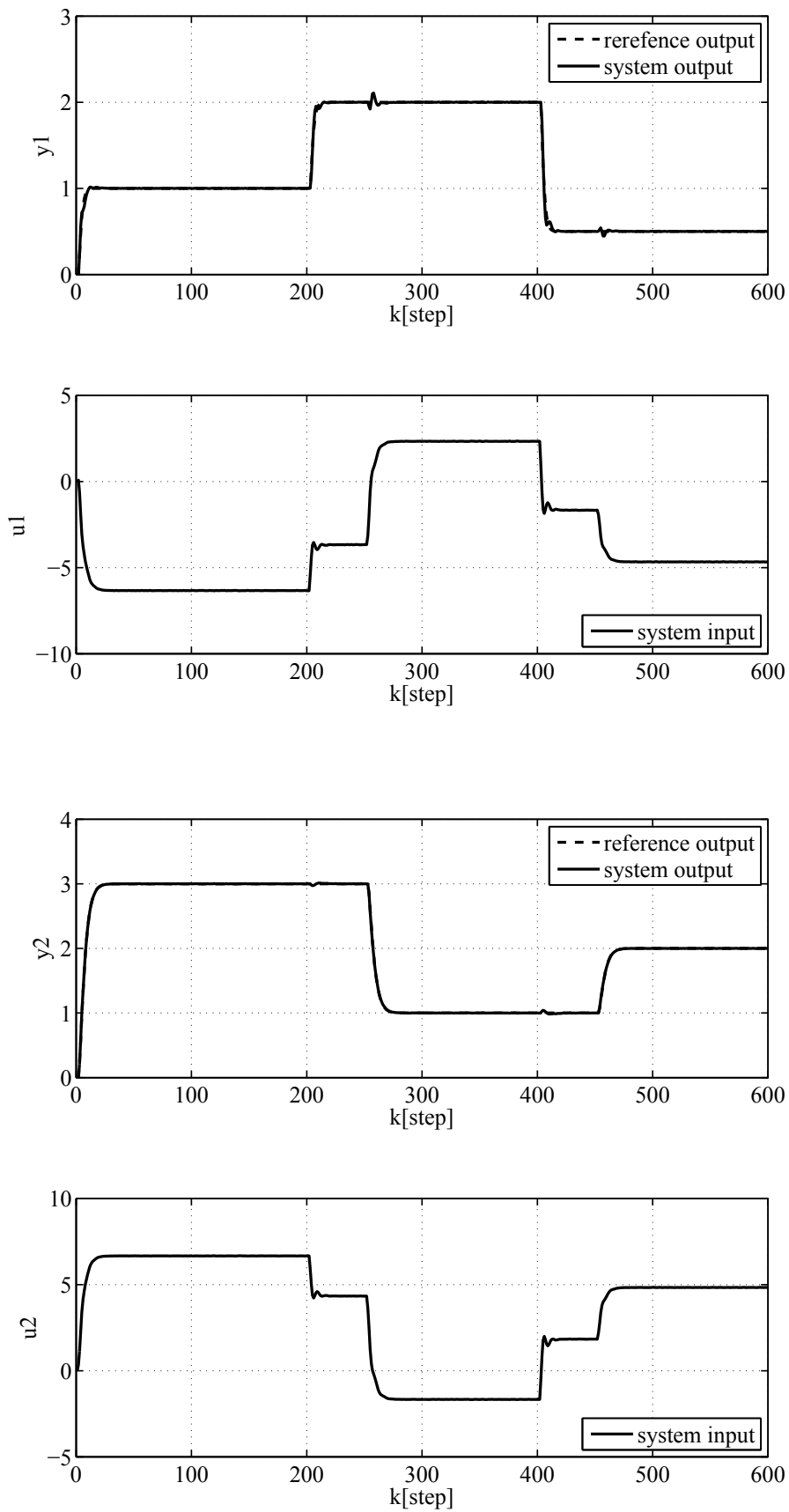

Fig. 3.3: Control result by using the proposed scheme when parameters are set $\lambda_1 = \lambda_2 = 1.00$ for Example 1.

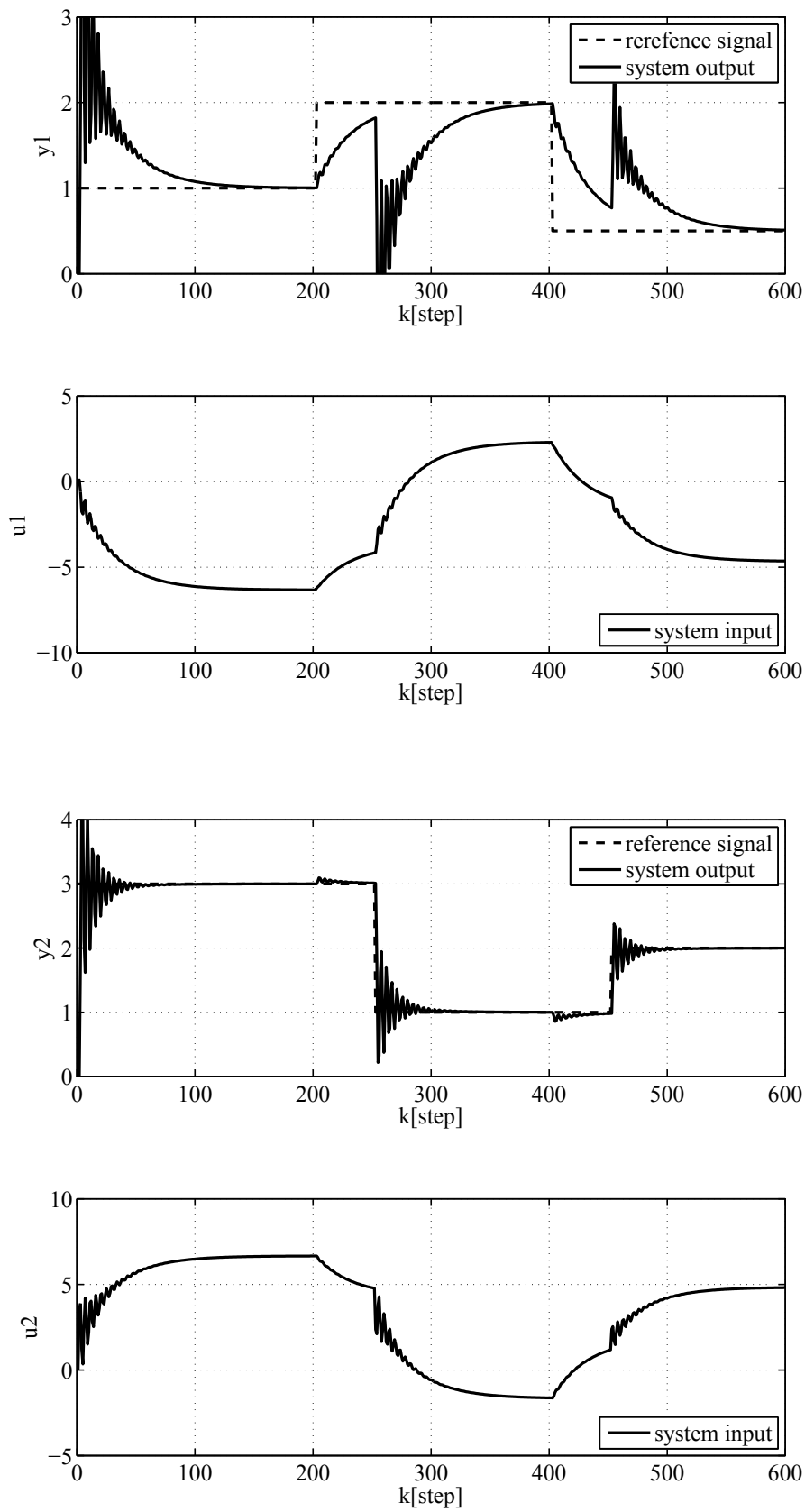

Fig. 3.4: Control result of other operating data for Example 1.

Next, the control performance for reference model design was considered.

When the rise time properties were set to $\sigma_1 = 10.0$ [s], $\sigma_2 = 20.0$ [s] and $\delta_1 = \delta_2 = 0.0$, the reference models were as follows:

$$G_{m_1}(z^{-1}) = \frac{0.03z^{-1}}{1 - 1.64z^{-1} + 0.67z^{-2}} \quad (3.29)$$

$$G_{m_2}(z^{-1}) = \frac{0.01z^{-1}}{1 - 1.81z^{-1} + 0.82z^{-2}}. \quad (3.30)$$

Fig. 3.5 shows the control. The reference model was set to $\delta_1 = 2.0$, $\delta_2 = 0.0$ and $\sigma_1 = 3.0$ [s], $\sigma_2 = 6.0$ [s], to verify the damping property, which obtained:

$$G_{m_1}(z^{-1}) = \frac{0.12z^{-1}}{1 - 1.53z^{-1} + 0.65z^{-2}} \quad (3.31)$$

$$G_{m_2}(z^{-1}) = \frac{0.08z^{-1}}{1 - 1.43z^{-1} + 0.51z^{-2}}. \quad (3.32)$$

Setting the parameters σ_j and δ_j upon construction of the reference model is important. These parameters are designed according to the system design specifications; in this case, σ_j was set to obtain an output with a faster rise time than that of the CHR method. The damping property was set to $\delta_j = 0$, to produce a stable follow-up performance.

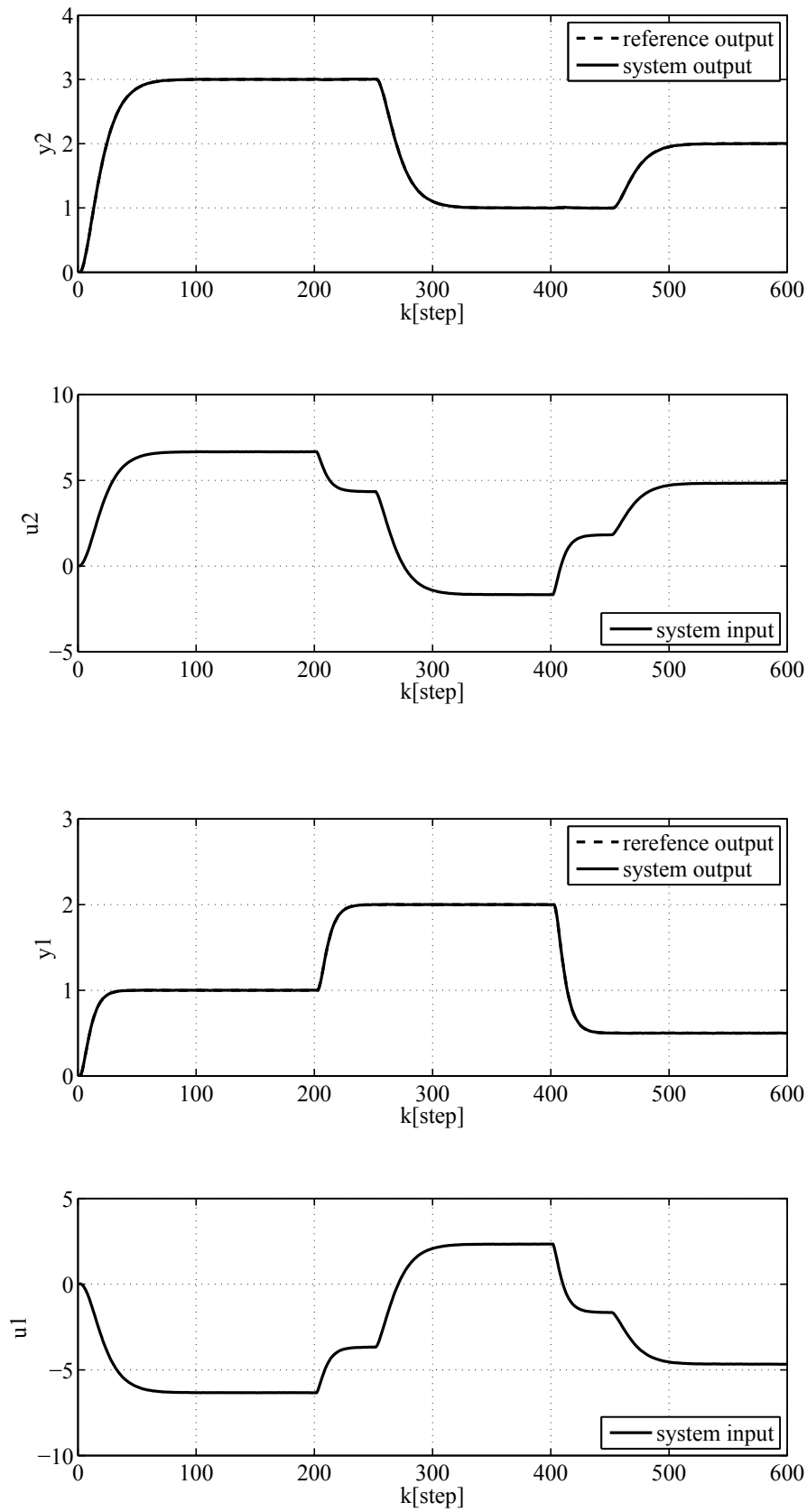

Fig. 3.5: Control result by using the proposed scheme when $\sigma_1 = 10.00$ and $\lambda_2 = 20.0$ for Example 1.

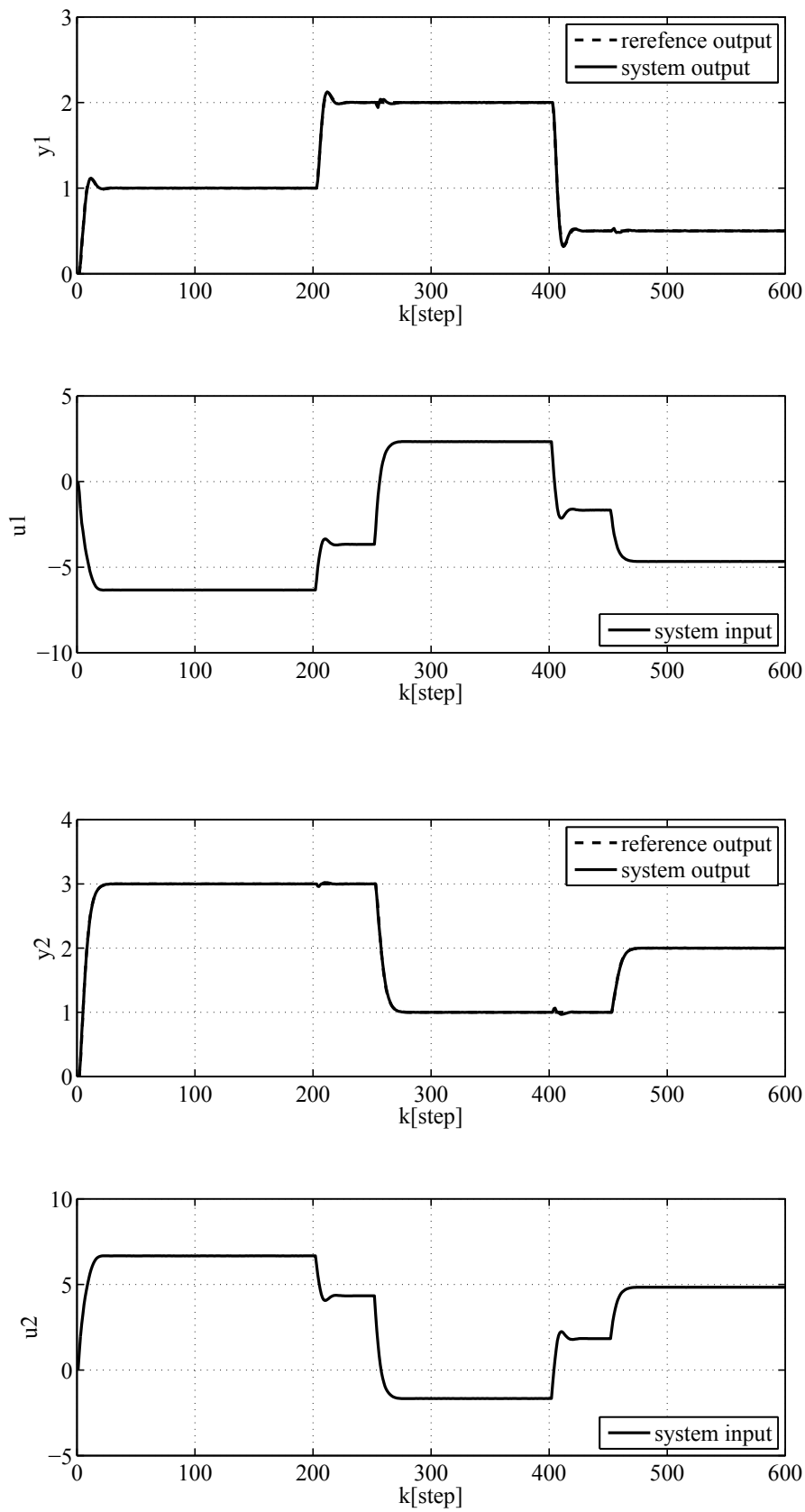

Fig. 3.6: Control result by using the proposed scheme when $\delta_1 = 2.0$ and $\delta_2 = 0.0$ for Example 1.

The weight parameter λ_j was also considered. Fig. 3.7 shows the control result from using the proposed scheme with $\lambda_1 = 1.00$ and $\lambda_2 = 0.01$. Fig. 3.2 shows the results using the operating data.

As shown in Fig. 3.7, when y_1 is weighted heavily, the interference of y_1 can be better suppressed. In contrast, this decreases the control performance of y_2 .

Table 3.1 shows the integral square errors about each output which were computed by changing λ_j . Here, ε_j is the error between the reference and the control outputs, and is defined by the following equation:

$$\varepsilon_j = G_{m_j}(z^{-1})r_j(k) - y_j(k). \quad (3.33)$$

Table 3.1: The sum of squared control error corresponding to the changing λ_j .

λ	$\int \varepsilon_1$	$\int \varepsilon_2$
$\lambda_1 = 0.01, \lambda_2 = 1.00$	0.178	0.013
$\lambda_1 = 1.00, \lambda_2 = 1.00$	0.177	0.021
$\lambda_1 = 1.00, \lambda_2 = 0.01$	0.007	1.056

Table 3.1 clearly shows that the proposed scheme obtained better performance by changing the weight rate so that λ_j worked properly. In particular, if an operator sets λ_j to match the operating conditions and system, the desired output can be obtained.

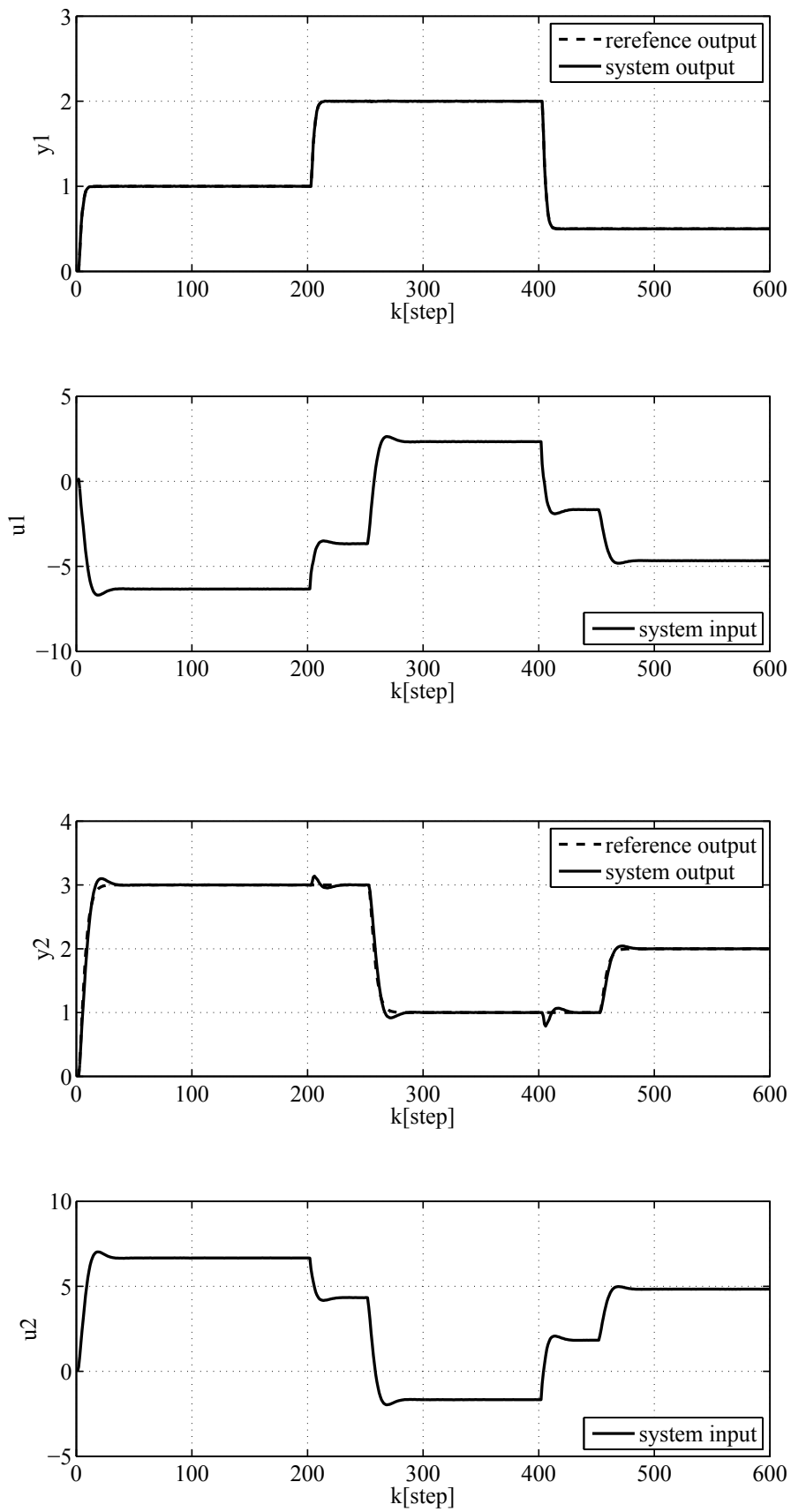

Fig. 3.7: Control result by using the proposed scheme when parameters are set $\lambda_1 = 1.00$ and $\lambda_2 = 0.01$.

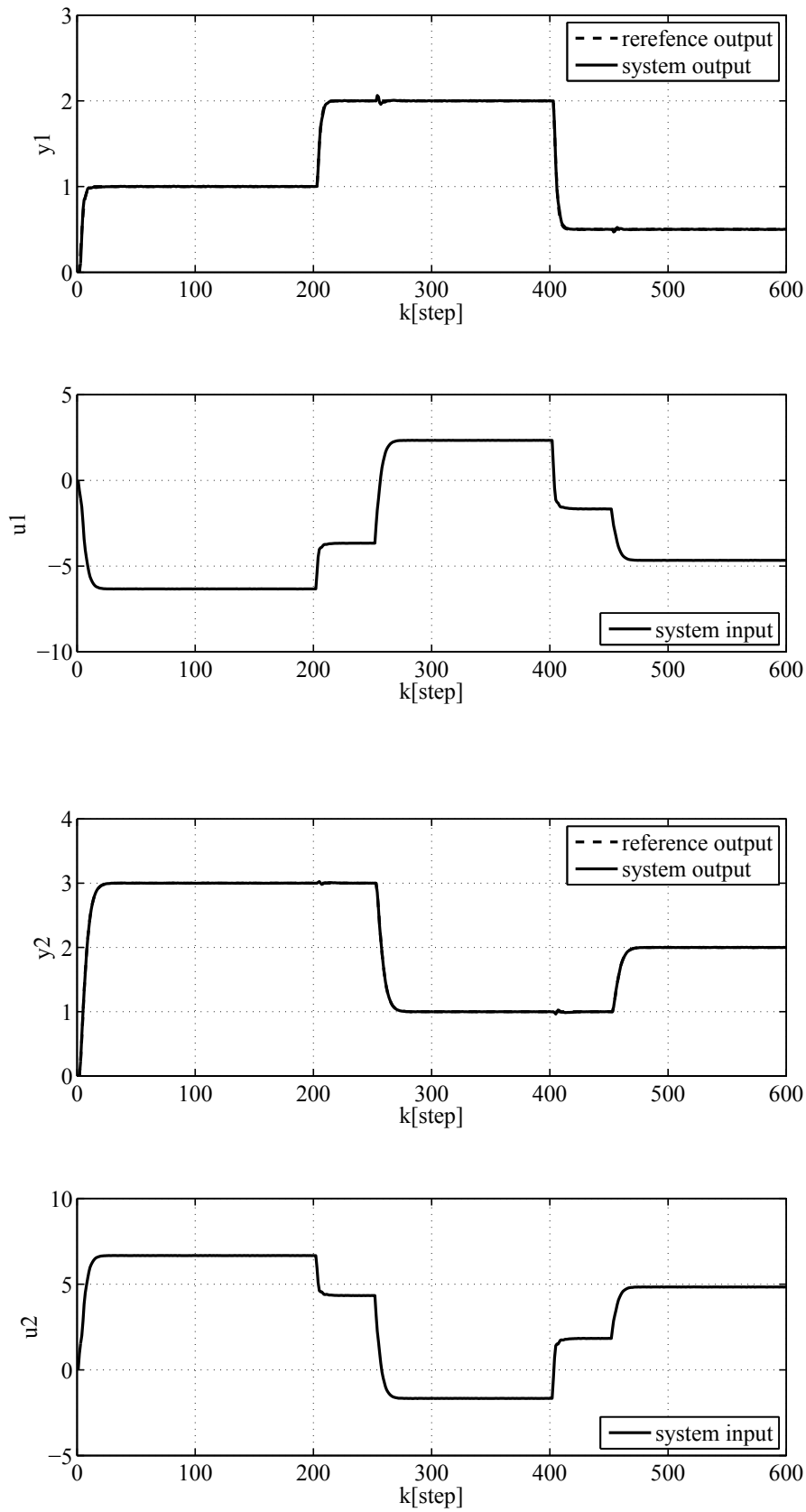

Fig. 3.8: Control result by using the proposed scheme when parameters are set $\lambda_1 = 0.01$ and $\lambda_2 = 1.00$ for Example 1.

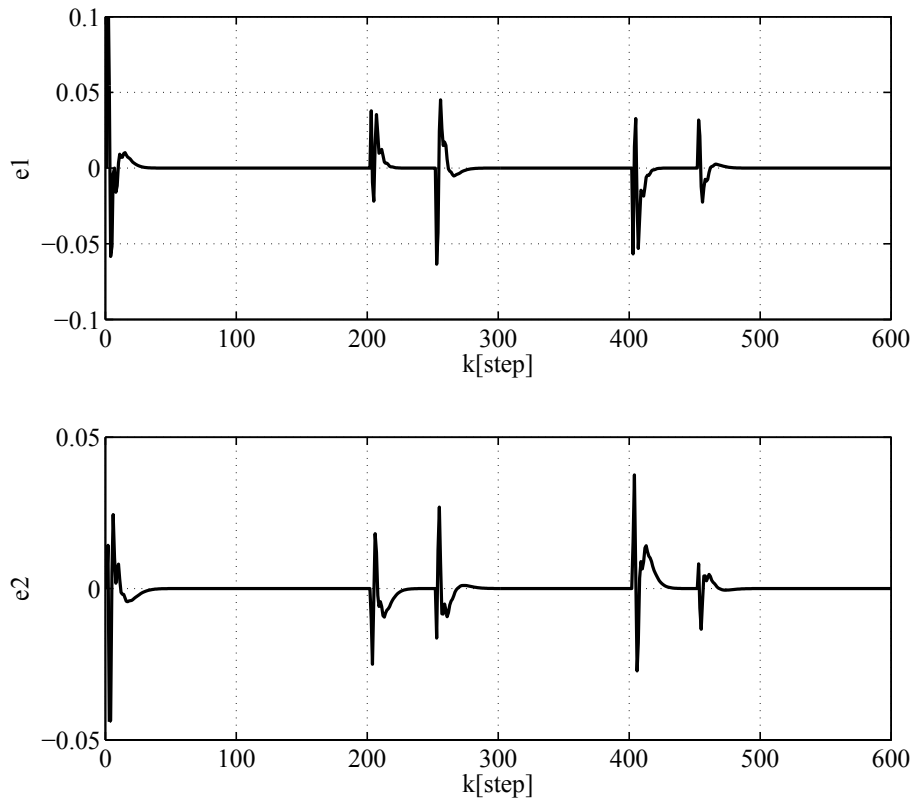

Fig. 3.9: The error by using the proposed scheme when $\lambda_1 = 1.0$ and $\lambda_2 = 1.0$ for Example 1.

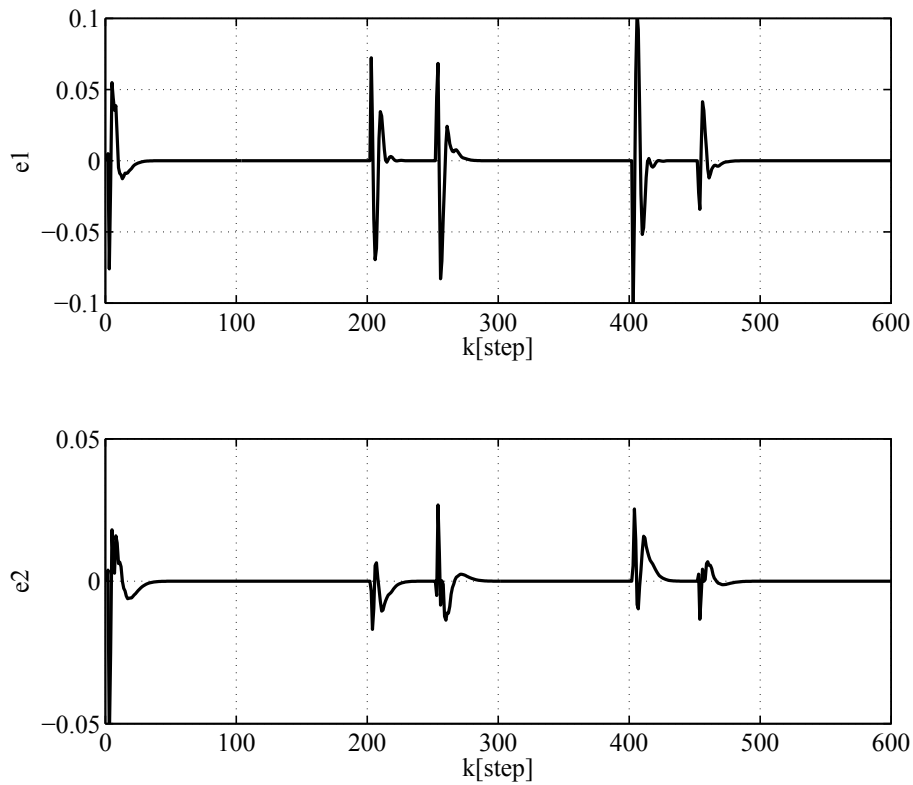

Fig. 3.10: The error by using the proposed scheme when $\lambda_1 = 0.01$ and $\lambda_2 = 1.0$ for Example 1.

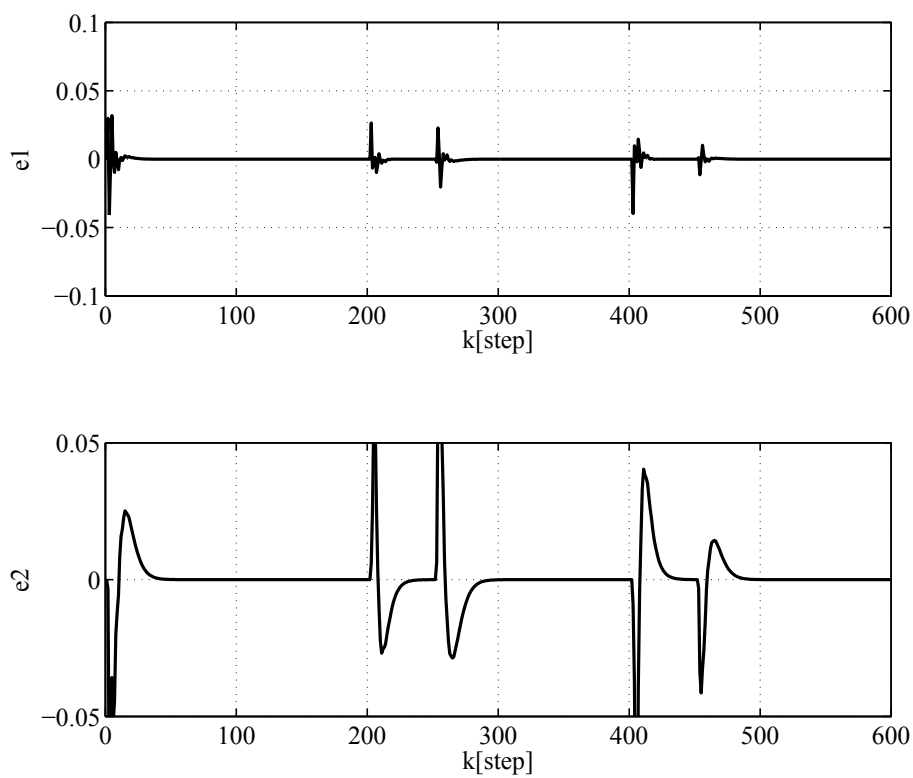

Fig. 3.11: The error by using the proposed scheme when $\lambda_1 = 1.0$ and $\lambda_2 = 0.01$ for Example 1.

3.3.2 Multivariable system including a time delay

Next, the following multivariable system, which included a time delay, was verified⁽⁶⁹⁾:

$$\begin{aligned} \mathbf{y}(k) = & \begin{bmatrix} 0.9 & 0.1 \\ -0.1 & 0.8 \end{bmatrix} \mathbf{y}(k-1) + \begin{bmatrix} 0.6 & 0.5 \\ -0.4 & 0.5 \end{bmatrix} \mathbf{u}(k-d-1) \\ & + \begin{bmatrix} 0.3 & 0.2 \\ -0.3 & 0.3 \end{bmatrix} \mathbf{u}(k-d-2) + \boldsymbol{\xi}(k) \end{aligned} \quad (3.34)$$

where $\boldsymbol{\xi}(s)$ is Gaussian white noise with a zero mean and variance of 0.01. The system has a time delay of $d = 5$ and was discretized by $T_s = 1.0$ [s]. However, operators can not know all of the system parameters, and the time delay is required for estimates with the PID gain matrix. Therefore, a time delay was obtained based on the concept presented in section 2.3.3 and equation (2.30).

First, the operating data were obtained. The following PID gain matrix, which was calculated by the CHR method, was applied to the system:

$$\mathbf{K}_P = \begin{bmatrix} 0.120 & 0 \\ 0 & 0.130 \end{bmatrix}, \mathbf{K}_I = \begin{bmatrix} 0.013 & 0 \\ 0 & 0.029 \end{bmatrix}, \mathbf{K}_D = \begin{bmatrix} 0.320 & 0 \\ 0 & 0.349 \end{bmatrix}. \quad (3.35)$$

The reference signals were given by

$$r_1(k) = \begin{cases} 1.0 & (0 \leq k \leq 150) \\ 2.0 & (150 < k \leq 250) \\ 0.5 & (250 < k \leq 400) \end{cases} \quad (3.36)$$

$$r_2(k) = \begin{cases} 1.0 & (0 \leq k \leq 50) \\ 2.0 & (50 < k \leq 450) \\ 1.5 & (450 < k \leq 400) \end{cases} \quad (3.37)$$

Fig. 3.12 shows the control results for this time delay system. Because equation (3.35) is not decoupled, y_1 and y_2 were influenced by each input/output. The outputs also oscillated.

The reference model $\mathbf{G}_m(z^{-1})$ was then designed according to user-specified parameters are: $\sigma_1 = 3.0$ [s], $\sigma_2 = 12.0$ [s] and $\delta_1 = \delta_2 = 0.0$. Therefore, the following equations were obtained:

$$G_{m_1}(z^{-1}) = \frac{0.11z^{-1}}{1 - 1.34z^{-1} + 0.45z^{-2}} \quad (3.38)$$

$$G_{m_2}(z^{-1}) = \frac{0.02^{-1}}{1 - 1.69z^{-1} + 0.72z^{-2}}. \quad (3.39)$$

λ was set to $\lambda_1 = 1.0$ and $\lambda_2 = 0.3$ because y_1 clearly included a larger control error than y_2 , as shown in Fig. 3.12. The proposed scheme was applied to the system, and d was determined to be $d = 5$ by the the generalized error in Table 3.2. It is the true d . Thus, the PID gain matrix in equation (3.40), was calculated, and Fig. 3.13 shows the control results of the proposed scheme.

$$\mathbf{K}_P = \begin{bmatrix} 0.154 & -0.008 \\ 0.110 & 0.114 \end{bmatrix}, \mathbf{K}_I = \begin{bmatrix} 0.015 & -0.011 \\ 0.022 & 0.001 \end{bmatrix}, \mathbf{K}_D = \begin{bmatrix} 0.266 & 0.229 \\ 0.123 & 0.430 \end{bmatrix} \quad (3.40)$$

In the results, y_1 remained oscillatory. However, the control response was greatly improved, and both outputs converged to the desired output.

Table 3.2: The generalized output error corresponding to each time delay.

d	generalized output error
1	4.276
2	2.486
3	2.379
4	1.891
5	1.749
6	3.619
7	6.324
8	10.244
9	17.041
10	24.832

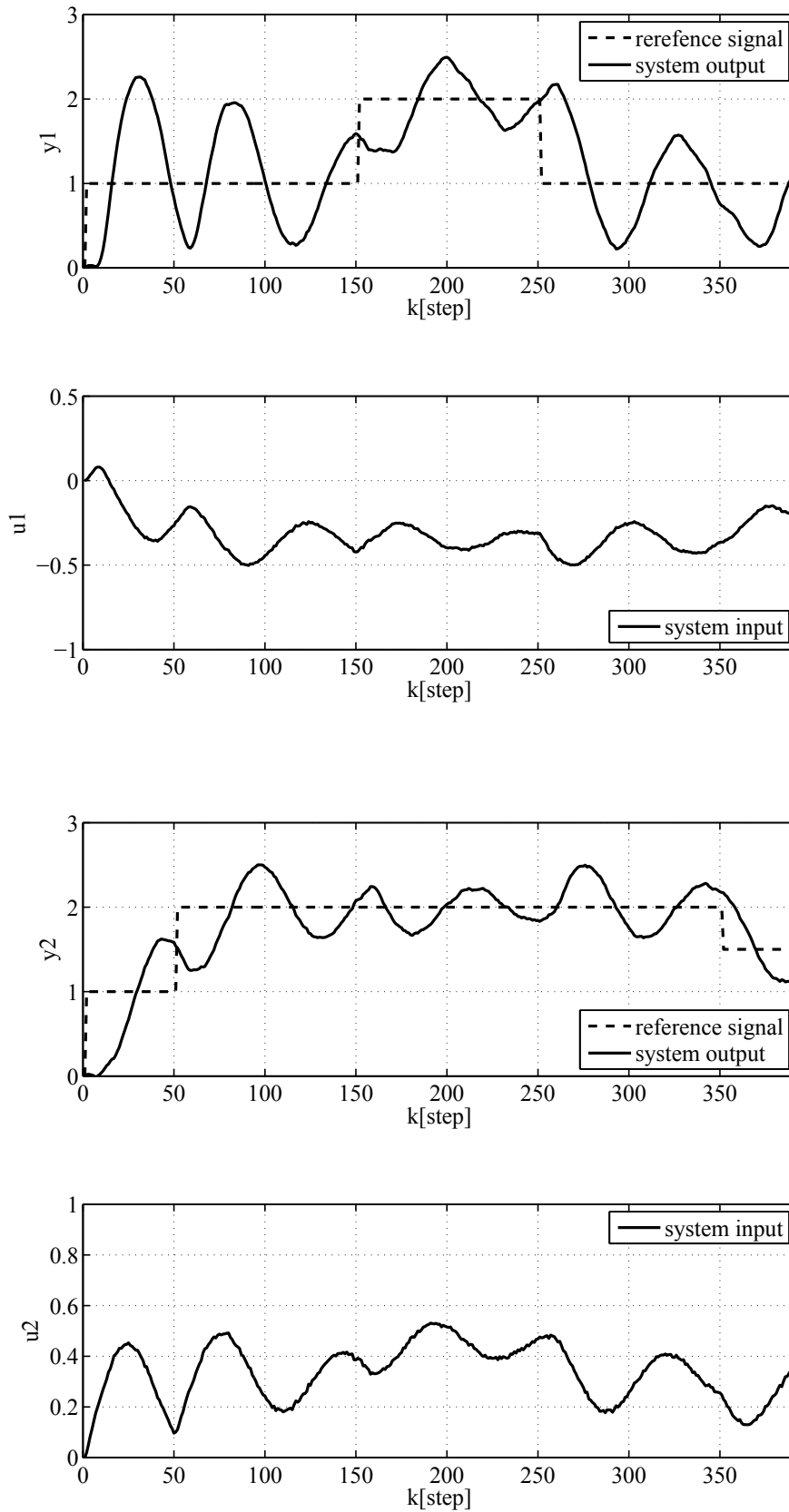

Fig. 3.12: Control result by using the CHR method for a time delay system.

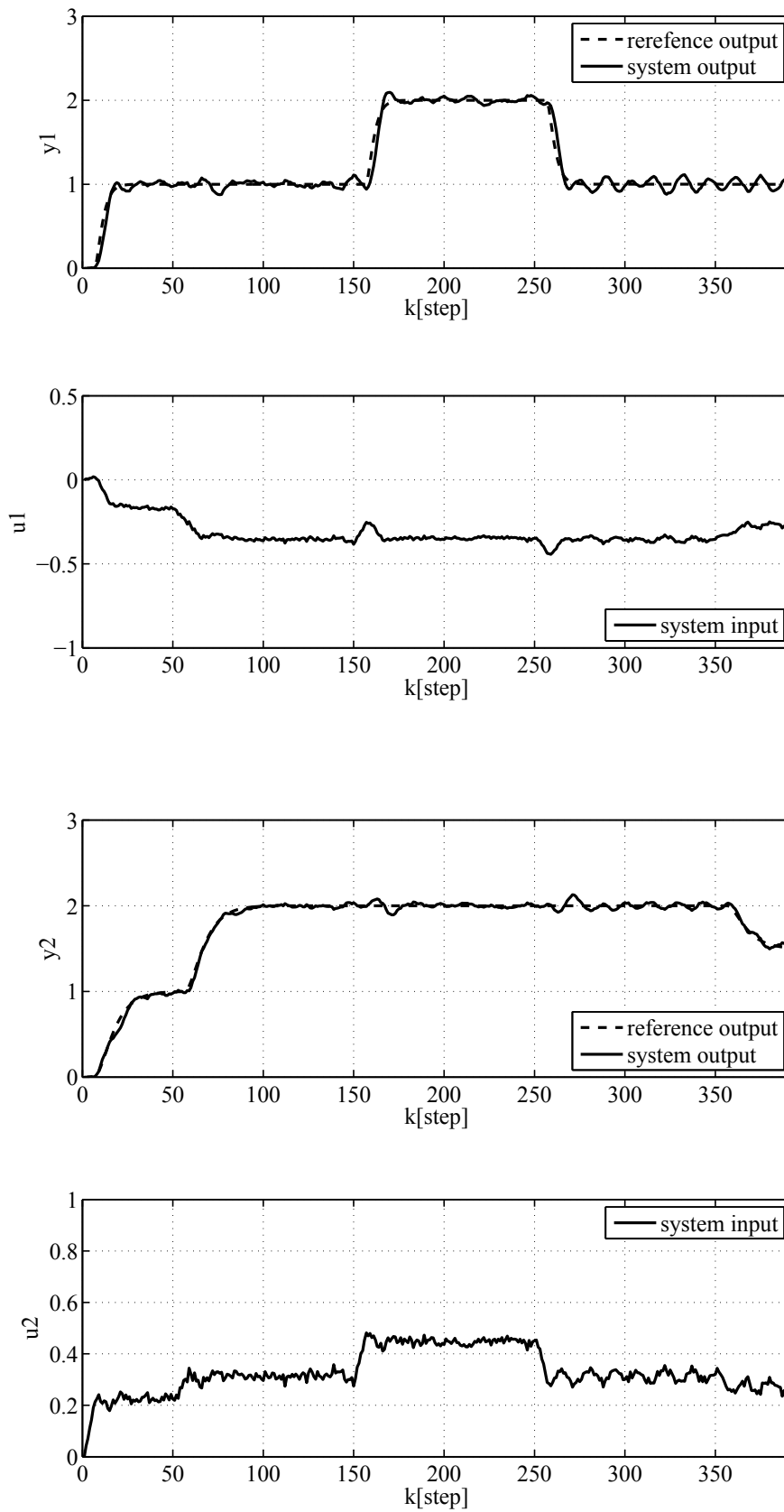

Fig. 3.13: Control result by using the proposed scheme for a time delay system.

3.3.3 Stirred reactor model

Finally, a system model of simplified stirred reactor model⁽⁶⁸⁾ was considered, as shown in Fig. 3.14.

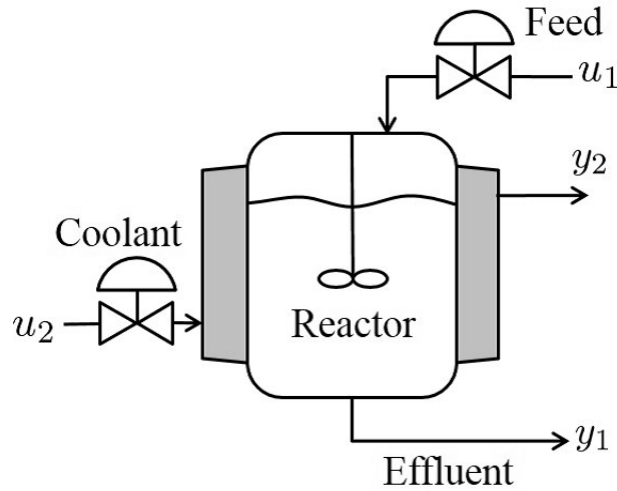

Fig. 3.14: Stirred tank reactor.

The system was considered to be continuous time two-input/two-output system is considered. $Y_1(s)$ and $Y_2(s)$ denote the effluent concentration and reactor temperature, respectively. $U_1(s)$ is the flow rate of the feed, and $U_2(s)$ is the flow rate of the coolant.

$$\begin{bmatrix} Y_1(s) \\ Y_2(s) \end{bmatrix} = \begin{bmatrix} \frac{1}{1+0.1s} & \frac{5}{1+s} \\ \frac{5}{1+0.5s} & \frac{2}{1+0.4s} \end{bmatrix} \begin{bmatrix} U_1(s) \\ U_2(s) \end{bmatrix} + \boldsymbol{\xi}(s), \quad (3.41)$$

$\boldsymbol{\xi}(s)$ is Gaussian white noise with a zero mean and variance of 0.01^2 . When discretized by $T_s = 0.01$, the following discrete-time model was obtained:

$$\begin{bmatrix} y_1(k) \\ y_2(k) \end{bmatrix} = \begin{bmatrix} \frac{0.10z^{-1}}{1-0.90z^{-1}} & \frac{0.05z^{-1}}{1-0.99z^{-1}} \\ \frac{0.20z^{-1}}{1-0.98z^{-1}} & \frac{0.05z^{-1}}{1-0.98z^{-1}} \end{bmatrix} \begin{bmatrix} u_1(k) \\ u_2(k) \end{bmatrix} + \boldsymbol{\xi}(k). \quad (3.42)$$

The PID control scheme was applied to the system, and the following PID gain matrix was

obtained by the CHR method.

$$\mathbf{K}_P = \begin{bmatrix} 0.72 & 0 \\ 0 & 0.36 \end{bmatrix}, \mathbf{K}_I = \begin{bmatrix} 0.05 & 0 \\ 0 & 0.06 \end{bmatrix}, \mathbf{K}_D = \begin{bmatrix} 1.80 & 0 \\ 0 & 3.60 \end{bmatrix} \quad (3.43)$$

The control results were shown in Fig. 3.15. The reference values were given by the following equations:

$$r_1(k) = \begin{cases} 0.1 & (0 \leq k \leq 100) \\ 0.7 & (100 \leq k \leq 200) \\ 0.8 & (200 \leq k \leq 300) \\ 0.2 & (300 < k \leq 600) \end{cases} \quad (3.44)$$

$$r_2(k) = \begin{cases} 0.2 & (0 \leq k \leq 400) \\ 0.3 & (400 < k \leq 600). \end{cases} \quad (3.45)$$

As shown in Fig. 3.15, y_1 had a good performance; however, the rising part of y_2 was oscillatory, and the output was affected by y_1 around $k = 300$.

The proposed scheme was applied using the control results, as shown in Fig. 3.15. Here, the reference models were designed as follows:

$$G_{m_1}(z^{-1}) = \frac{0.05z^{-1}}{1 - 1.55z^{-1} + 0.61z^{-2}} \quad (3.46)$$

$$G_{m_2}(z^{-1}) = \frac{0.03z^{-1}}{1 - 1.64z^{-1} + 0.67z^{-2}}. \quad (3.47)$$

The coefficients were determined by setting $T_s = 0.01$ [s], $\sigma_1 = 0.08$, $\sigma_2 = 0.10$, and $\delta_1 = \delta_2 = 0.0$.

Fig. 3.16 shows the control results using the proposed scheme, and the following equation is the computed PID gain matrix. The results clearly shows that the desired output can be obtained and the y_2 can be decoupled.

$$\mathbf{K}_P = \begin{bmatrix} 2.54 & -1.43 \\ -0.72 & 3.21 \end{bmatrix}, \mathbf{K}_I = \begin{bmatrix} 0.32 & -0.14 \\ -0.09 & 0.32 \end{bmatrix}, \mathbf{K}_D = \begin{bmatrix} 5.71 & -4.16 \\ -1.21 & 9.31 \end{bmatrix} \quad (3.48)$$

Therefore, the proposed scheme was demonstrated to be effective.

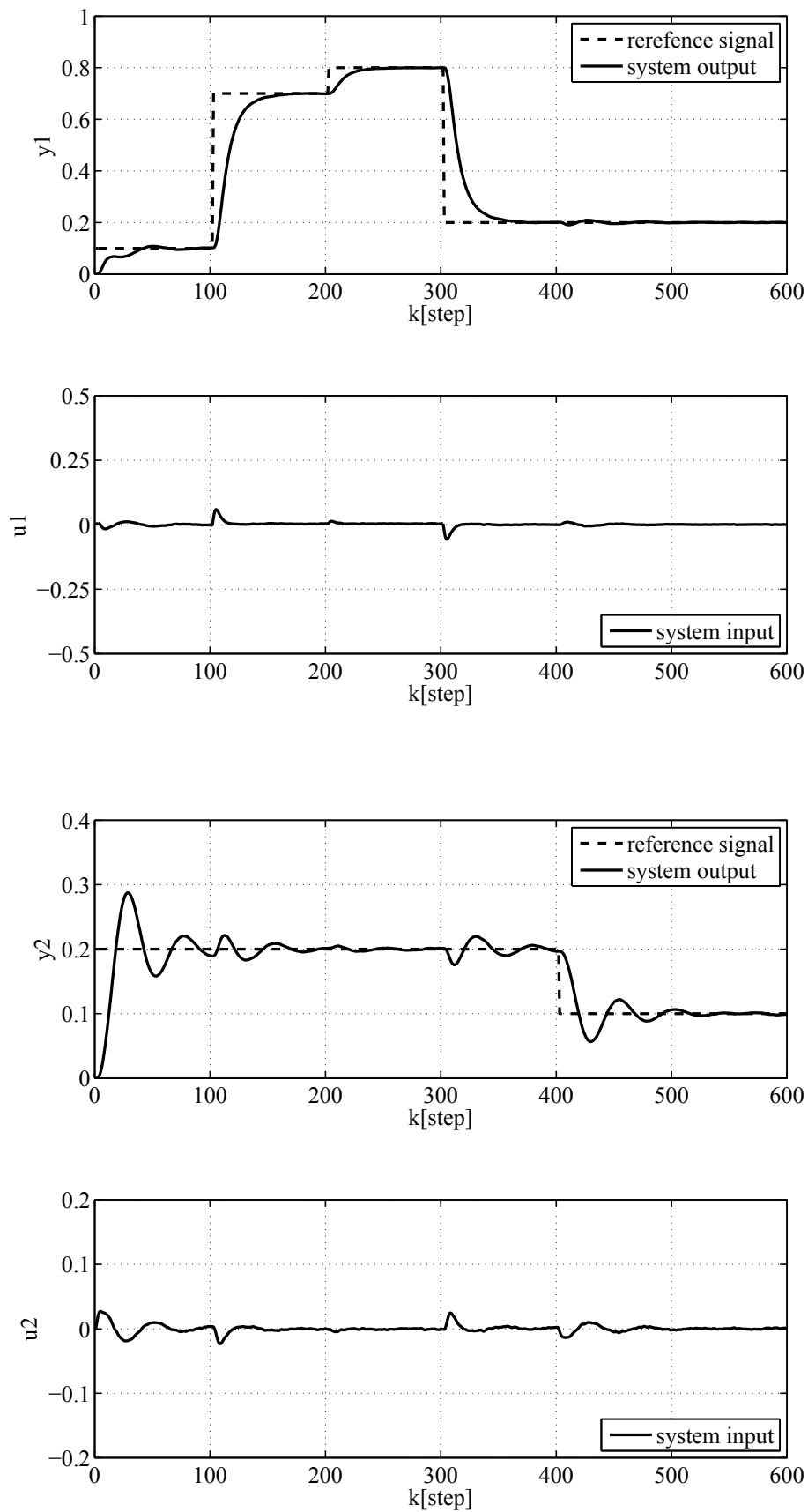

Fig. 3.15: Control result by using the CHR method for a stirred reactor model.

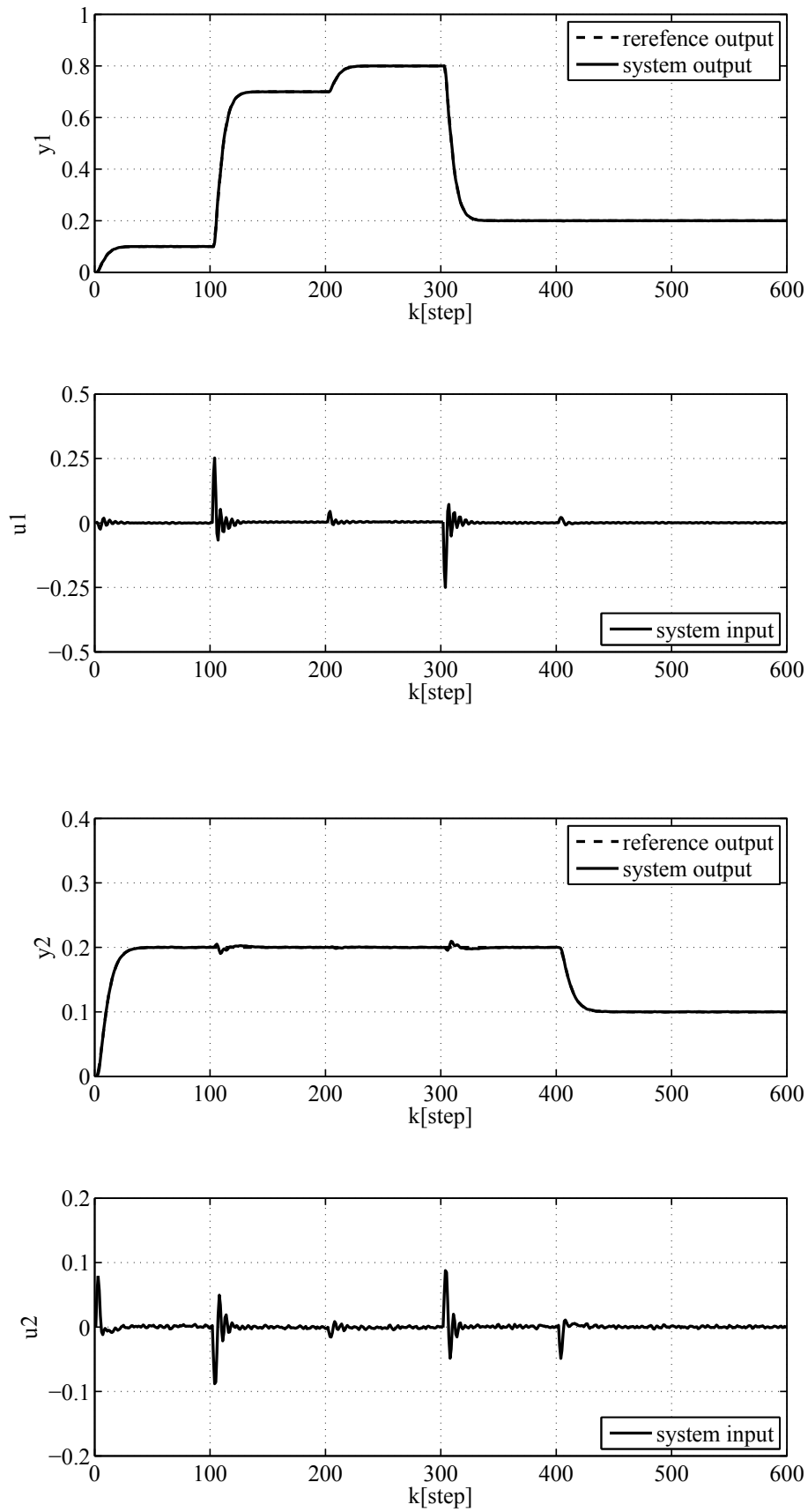

Fig. 3.16: Control result by using the proposed scheme for a stirred reactor model.

3.4 Conclusions

This chapter has presented a data-oriented multivariable PID control system, because real processes are often given by MIMO systems. The behavior of the proposed scheme has been examined by numerical simulation examples. The proposed scheme has the following features:

- PID gains can be directly calculated using operating data for multivariable systems without a system model.
- Non-diagonal elements of the PID gain matrix are computed to reduce interference for each input and output.
- The output signal can converge to the desired reference signal without depending on the type of operating data.
- By adjusting the weight λ , a obtain control performance which matches the operating conditions can be obtained.

Chapter 4

Design of a PID controller for nonlinear systems

4.1 Introduction

Chapter 4 presents a nonlinear system for the design of a data-oriented control scheme. Chapters 2 and 3 discussed a controller for a linear system. However, most systems are nonlinear, and obtaining the desired control results by using a fixed PID controller is difficult. Thus, many nonlinear control design methods have been proposed^(70–77,80). Most schemes describe the nonlinearly in some way. For example, the neural network (NN)^(38,81–85) and cerebellar model articulation controller (CMAC)^(88–90) have been demonstrated to be effective for nonlinear systems; and most notably, the FRIT-CMAC PID controller⁽⁹¹⁾ can use the operating data directly for the design. One of the proposed methods is a data-driven PID controller^(79,86,87). In the method, data approximating the current state are collected from a database of past results. In particular, the method stores data on the operating state of the system, and neighbors are computed by comparing the data with information requests, which are called 'queries'. The local controller is constructed using these neighbors. A set of suitable PID gains is self-adjusted to the system status using the selected data, and the local controller is designed. However, in order to accumulate data, experiments to be performed in an online manner, which complicates the implementation of the controllers.

In contrast, the proposed data-oriented control design is based on the generalized output defined by the PID control law. The proposed scheme can obtain a set of suitable PID gains

to converges the desired reference output by using operating data without a system model. However, the scheme cannot work well for nonlinear systems because the obtained PID gains are fixed. Therefore, PID gains should be adjustable for nonlinear systems.

This chapter expands the previous scheme to nonlinear systems based on the idea of a data-driven control scheme. According to the proposed scheme, an online database does not need to be created because it will be created offline. Thus, one or both problems with implementation can be solved. The usefulness of the proposed scheme is verified by two numerical examples

4.2 Design of a control system

4.2.1 Data-driven control scheme

First, the general data-oriented control method is explained. The system is as follows:

$$y(k) = f(\theta(k-1)). \quad (4.1)$$

$y(k)$ and $f(\cdot)$ denote the system output and nonlinear function, respectively. Similarly, $\theta(k-1)$ expresses hysteretic data, which is the condition previous to the system time k , and is given by the following equation:

$$\theta(k-1) = [y(k-1), \dots, y(k-n_y), u(k-1), \dots, u(k-n_u-1)] \quad (4.2)$$

where $u(k)$ denotes the control input and n_y and n_u are the system a dimensions of each output and input. In the data-driven control approach, the input/output data are stored in the database as hysteretic data. A query, which is a vector at time k , is constructed from the stored database, and a local linear model is designed by using the query and neighbors around the query.

4.2.2 The description of a system

Consider the following PID control law:

$$\Delta u(k) = K_I(k)e(k) - K_P(k)\Delta y(k) - K_D(k)\Delta^2 y(k) \quad (4.3)$$

$$e(k) = r(k) - y(k). \quad (4.4)$$

Here, $u(k)$, $y(k)$, and $r(k)$ are the control input, control output corresponding reference signal, respectively. Similarly, Δ denotes the difference operator and is defined by $\Delta := 1 - z^{-1}$.

$K_P(k)$, $K_I(k)$, and $K_D(k)$ denote the proportional, integral and derivative gains, respectively. PID gains must vary with the system properties because many process systems are nonlinear.

Based on the method described in chapter 2, the generalized output $\Phi(k)$ is defined as follows:

$$\Phi(k) = a_1(k)\Delta u(k) + a_2(k)y(k) + a_3(k)y(k-1) + a_4(k)y(k-2) \quad (4.5)$$

with the parameters $a_i(k)$ ($i = 1, \dots, 4$) are

$$\left. \begin{aligned} a_1(k) &= \frac{1}{K_I(k)} \\ a_2(k) &= \frac{K_P(k) + K_I(k) + K_D(k)}{K_I(k)} \\ a_3(k) &= -\frac{K_P(k) + 2K_D(k)}{K_I(k)} \\ a_4(k) &= \frac{K_D(k)}{K_I(k)}. \end{aligned} \right\} \quad (4.6)$$

In this scheme, the parameters $a_i(k)$ ($i = 1, \dots, 4$) of $\Phi(k)$ are optimized so that $G_m(z^{-1})\Phi(k)$ is equivalent to $y(k)$ of the operating data. In other words, the generalized output error indicates the error between the operating data and $G_m(z^{-1})\Phi(k)$. The following evaluation function J is given:

$$J = \frac{1}{N} \sum_{k=1}^N \{y(k) - \hat{y}_m(k)\}^2 \quad (4.7)$$

$$\hat{y}_m(k) = G_m(z^{-1})\Phi(k) \quad (4.8)$$

4.2.3 Proposed scheme

In the data-driven PID controller, the past information is presented as an information vector, and these vectors are accumulated for some specified iterations. A vector is applied as close to the current state of the database as possible: thus, this vector is called neighbor data. A local controller is designed from the neighbors and the output value is predicted. In this scheme, the database is constructed from generalized output using the operating data; thus, this operation can be conducted online. The proposed method is explained below in detail; a diagram is shown in Fig. 4.1.

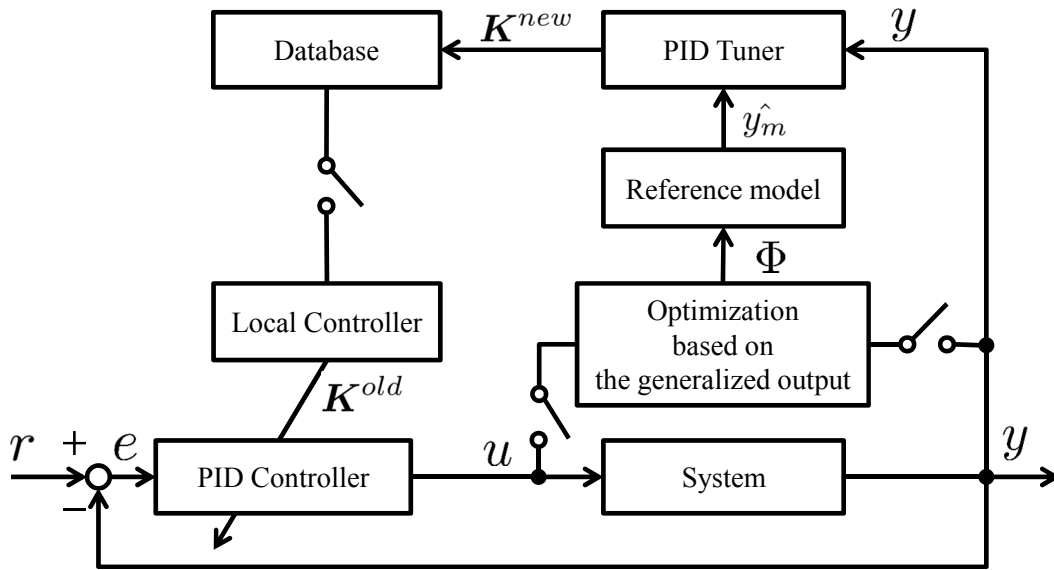

Fig. 4.1: Block diagram of the proposed nonlinear PID control system.

Step 1. Get operating data

The data-driven technique cannot work well if the database has not stored enough historical data. Thus, various reference signals need to be determined for the system. Initial PID gains are applied to obtain the corresponding operating data.

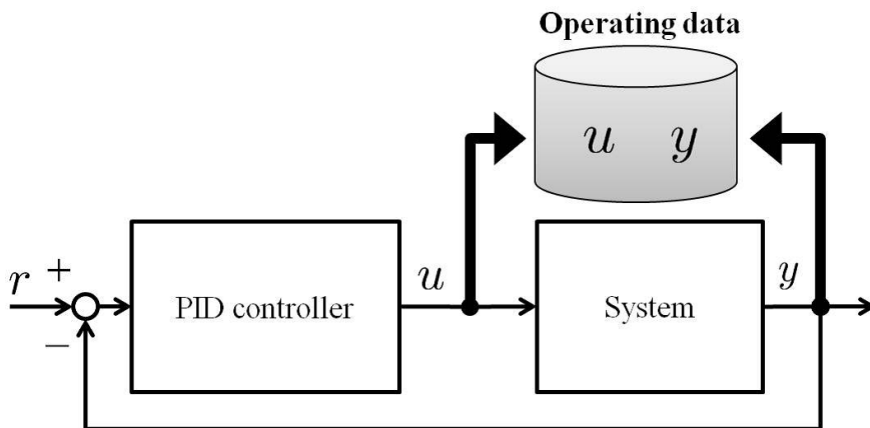

Fig. 4.2: Get an operating data

Step 2. Create an initial database

Parameters $a_i (i = 1, \dots, 4)$ of $\Phi(k)$ are calculated to converge to J in equation (4.7) using the operating data from Step 1. In particular, PID gains are computed. Then, an information vector is composed from the PID gains: the corresponding $r(k)$, $\hat{y}_m(k)$, $\hat{\varepsilon}(k)$, and $\Delta\hat{\varepsilon}(k)$. The initial database $\Theta(i)$ shown in the following equation is then constructed from these vectors;

$$\Theta(i) := [\bar{\theta}(i), \mathbf{K}(i)] \quad (i = 1, 2, \dots, N(0)). \quad (4.9)$$

Here, $\bar{\theta}(i)$ is given as follows:

$$\bar{\theta}(i) := [r(k), \hat{y}_m(k), \hat{\varepsilon}(k), \Delta\hat{\varepsilon}(k)]. \quad (4.10)$$

$\hat{\varepsilon}(k)$ is the generalized output error and is given by the following equation:

$$\hat{\varepsilon}(k) = y(k) - \hat{y}_m(k). \quad (4.11)$$

$N(0)$ denotes the number of data points in the initial database, while $\mathbf{K}(i)$ denotes the vector of the corresponding PID gains at time i , which is given by the following equation:

$$\mathbf{K}(i) := [K_P(i), K_I(i), K_D(i)]. \quad (4.12)$$

Step 3. Calculate distances and select neighbors

The query $\bar{\theta}(i)$ is defined as the system output $y(k)$ at time k . The distance between the query and the information vector $\theta(i)$ in the database is calculated as follows:

$$d(\theta(k), \bar{\theta}(i)) = \sum_{l=1}^4 \left| \frac{\theta_l(k) - \bar{\theta}_l(i)}{\max \bar{\theta}_l(M) - \min \bar{\theta}_l(M)} \right| \quad (i = 1, 2, \dots, N(k)) \quad (4.13)$$

where $N(k)$ denotes the number of data points in the database in time k . Similarly, the $\theta_l(k)$ is l -th element in the database at time k , and $\bar{\theta}_l(i)$ is the l -th element in the i -th information vector. $\max \bar{\theta}_l(M)$ and $\min \bar{\theta}_l(M)$ are the maximum and the minimum values, respectively in the l -th of all information vectors. The value of the elements is normalized in the denominator of equation (4.13).

Next, M vectors are selected from the smallest by using the distance d obtained from equation (4.13); these vectors are used for the neighbor data⁽⁷⁹⁾.

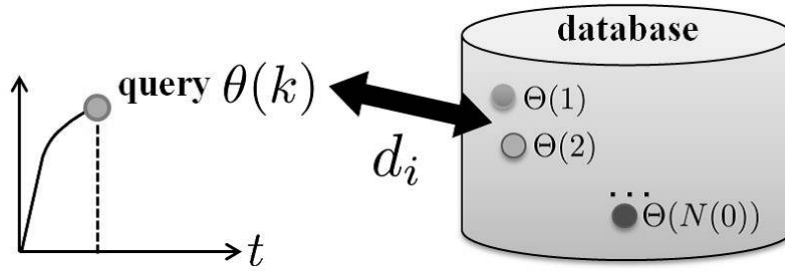

Fig. 4.3: Calculate distances between a query and information vectors

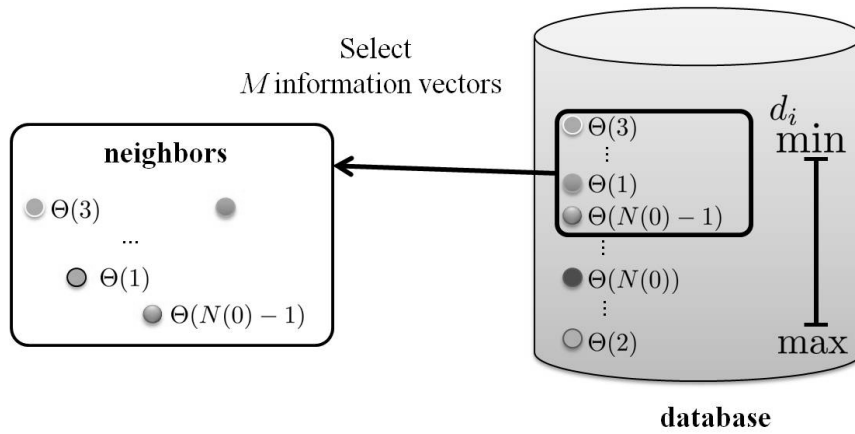

Fig. 4.4: Selection neighbors based on the distance

Step 4. Design a local controller

The local controller is designed according to the neighbors selected in Step 3 using a weighted local linearizing average method.

$$\mathbf{K}^{\text{old}}(k) = \sum_{i=1}^M w_i \mathbf{K}(i) \quad (4.14)$$

where w_i denotes the selected weight of the i -th neighbor information and is given by the following equation:

$$w_i = \frac{\frac{1}{d_i}}{\sum_{i=1}^M \frac{1}{d_i}}. \quad (4.15)$$

Here, d_i is the distance between the i -th neighbor and the local point in equation (4.13). From this equation, the weight increases the closer it approached current condition; in other words, the vector becomes more important.

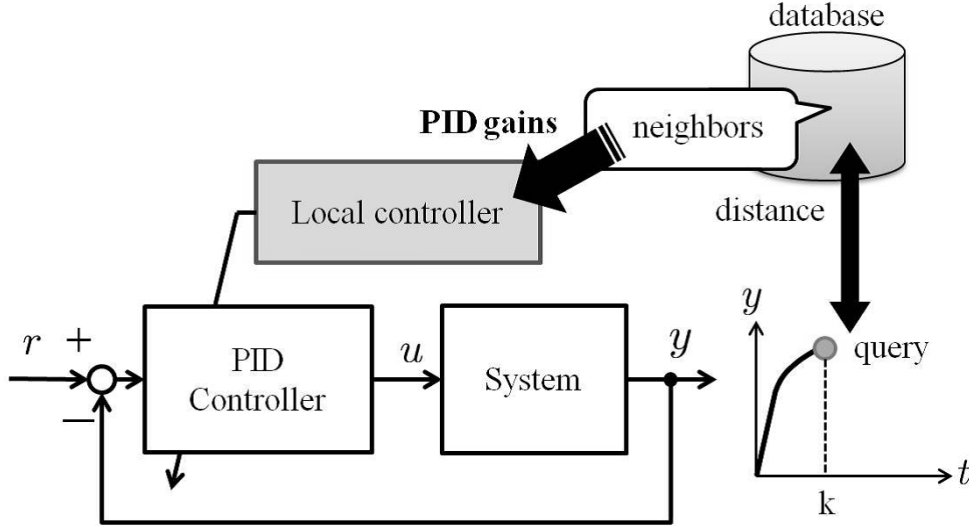

Fig. 4.5: Design a local controller

Step 5. Adjust PID gains

The PID gains \mathbf{K}^{old} in Step 4. are modified by the steepest descent method using equation (4.16) to calibrate the PID gain to the current state of the system. \mathbf{K}^{old} is adjusted to correspond to the error size. The new PID gains \mathbf{K}^{new} and corresponding information vector are then stored in the database:

$$\mathbf{K}^{\text{new}}(k) = \mathbf{K}(k)^{\text{old}} - \boldsymbol{\eta} \frac{\partial J_{\text{adj}}(k+1)}{\partial \mathbf{K}(k)}, \quad (4.16)$$

where $\boldsymbol{\eta}$ denotes the learning coefficient vector and is given by

$$\boldsymbol{\eta} = [\eta_P, \eta_I, \eta_D]. \quad (4.17)$$

The second term on the right side of equation (4.16) is developed as follows:

$$\left. \begin{aligned} \frac{\partial J(k+1)}{\partial K_P(k)} &= \frac{\partial J(k+1)}{\partial \hat{\varepsilon}(k+1)} \frac{\partial \hat{\varepsilon}(k+1)}{\partial \hat{y}_m(k+1)} \frac{\partial \hat{y}_m(k+1)}{\partial \Phi(k)} \frac{\partial \Phi(k)}{\partial K_P(k)} \\ \frac{\partial J(k+1)}{\partial K_I(k)} &= \frac{\partial J(k+1)}{\partial \hat{\varepsilon}(k+1)} \frac{\partial \hat{\varepsilon}(k+1)}{\partial \hat{y}_m(k+1)} \frac{\partial \hat{y}_m(k+1)}{\partial \Phi(k)} \frac{\partial \Phi(k)}{\partial K_I(k)} \\ \frac{\partial J(k+1)}{\partial K_D(k)} &= \frac{\partial J(k+1)}{\partial \hat{\varepsilon}(k+1)} \frac{\partial \hat{\varepsilon}(k+1)}{\partial \hat{y}_m(k+1)} \frac{\partial \hat{y}_m(k+1)}{\partial \Phi(k)} \frac{\partial \Phi(k)}{\partial K_D(k)} \end{aligned} \right\} \quad (4.18)$$

where

$$\left. \begin{aligned} \frac{\partial \Phi(k)}{\partial K_P(k)} &= \frac{y(k) - y(k-1)}{K_I} \\ \frac{\partial \Phi(k)}{\partial K_I(k)} &= \frac{(K_P + 2K_D)y(k-1) - \Delta u(k) - (K_P + K_D)y(k) - K_D y(k-2)}{K_I^2} \\ \frac{\partial \Phi(k)}{\partial K_D(k)} &= \frac{y(k) - 2y(k-1) + y(k-2)}{K_I} \end{aligned} \right\} \quad (4.19)$$

$J_{\text{adj}}(k+1)$ defines the evaluated error function as follows:

$$J_{\text{adj}}(k+1) = \frac{1}{2} \hat{\varepsilon}^2(k+1). \quad (4.20)$$

Step 6. Delete redundant data

In Step 5, collecting calculated \mathbf{K}^{new} and corresponding data increases the database size and the computational cost. Therefore, redundant data needs to be deleted from database. Redundant data are defined as meet the following conditions:

$$d_i(\theta(k), \theta(\bar{i})) \leq \alpha_1 \quad (4.21)$$

$$\sum_{l=1}^3 \left\{ \frac{\mathbf{K}_l(i) - \mathbf{K}_l^{\text{new}}}{\mathbf{K}_l(i)} \right\}^2 \leq \alpha_2. \quad (4.22)$$

The former condition indicates that the vector is similar to the neighbor data, and the latter condition indicates that the vector includes data close to \mathbf{K}^{new}

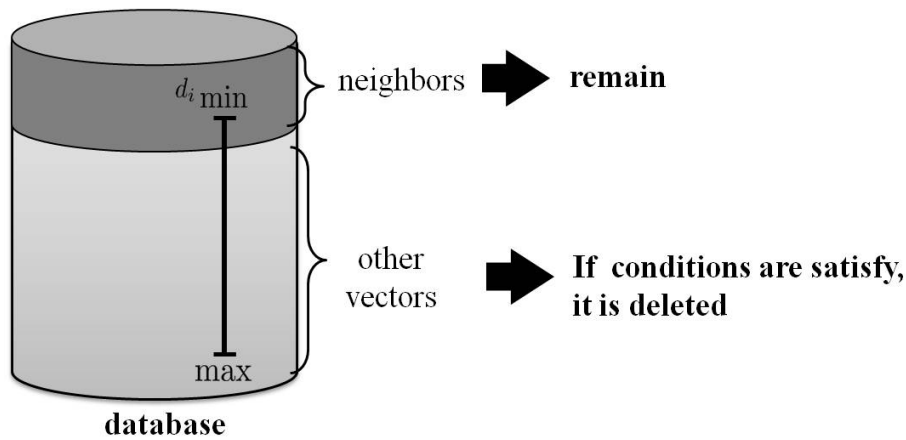

Fig. 4.6: Deletion of a redundant data

Step 7. Complete learning

The following equation (integral of squared error; ISE) indicates the progress in the learning situation. Steps 3. are repeated until the evaluated value converges.

$$\text{ISE} = \sum_{k=1}^N \hat{\varepsilon}^2(k). \quad (4.23)$$

Step 8. Design a control system

In the above Steps(2. - 7.), the database is constructed in an offline manner, moreover, the obtained database stores information vectors which include the system characteristics. A control system can be designed based on equation (4.14) using the database.

Therefore, the proposed scheme designs a PID controller system as follows. First, the database stores information vectors while learning the generalized output errors using the operating data in an offline manner. To control the system, the proposed scheme next selects information vectors near a query (*i.e.* current condition) from the database. PID gains are computed using these vectors, and the PID local controller is designed and applied. If the proposed scheme starts not working well, this may be caused by fluctuating system properties. Therefore, the database is reconstructed after the operating data are obtained again.

4.3 Simulation Examples

In order to evaluate the effectiveness of the proposed scheme, some numerical simulation examples are provided.

4.3.1 Hammerstein Model 1

First, the Hammerstein model⁽⁹²⁾ is given by the following equation:

$$\left. \begin{aligned} y(k) &= 0.6y(k-1) - 0.1y(k-2) + 1.2x(k-1) - 0.1x(k-2) + \xi(k) \\ x(k) &= 1.5u(k) - 1.5u^2(k) + 0.5u^3(k) \end{aligned} \right\} \quad (4.24)$$

where $\xi(k)$ is Gaussian white noise with a zero mean and variance of 0.01^2 . The static property is shown in Fig. 4.7, and from Fig. 4.7, where the system is clearly nonlinear and has a dead band from $u = 0.5$ to $u = 1.5$.

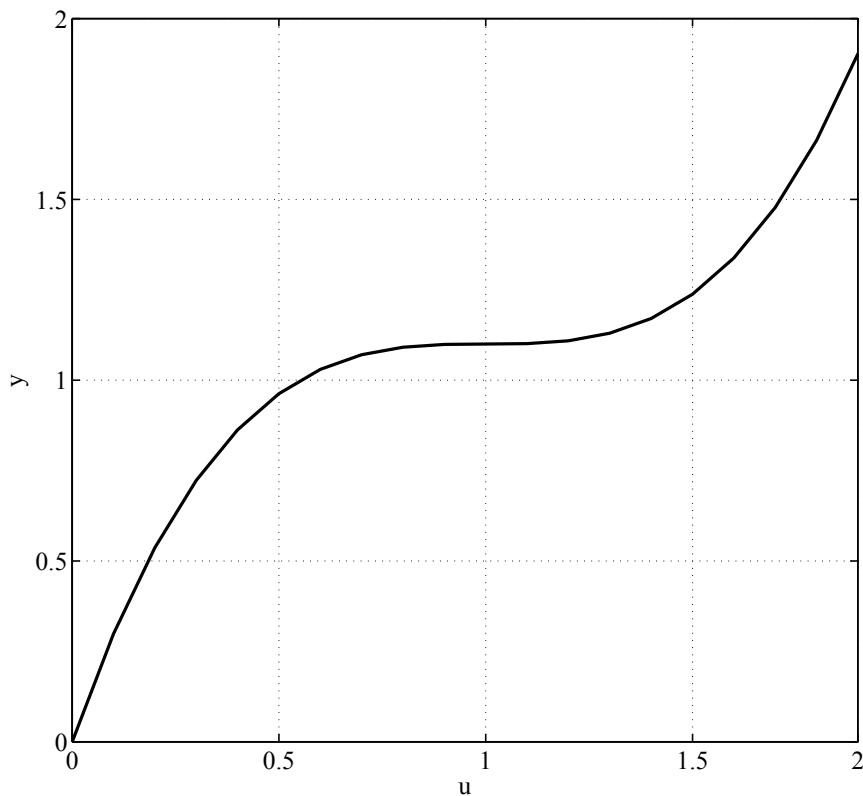

Fig. 4.7: The static characteristics of Hammerstein model 1

The operating data were obtained from the following fixed PID gains, and the reference signal $r(k)$ is given by equation (4.26). The PID gains were computed by using the Chien, Hrones & Reswick (CHR) method⁽¹¹⁾.

$$K_P = 0.486, K_I = 0.227, K_D = 0.122 \quad (4.25)$$

$$r(k) = \begin{cases} 0.5 & (0 < k \leq 50) \\ 1.0 & (50 < k \leq 100) \\ 2.0 & (100 < k \leq 150) \\ 1.5 & (150 < k \leq 200). \end{cases} \quad (4.26)$$

The control results are shown in Fig. 4.8. The response became slow when the system had a high gain because the PID gains adjusted to the dead band.

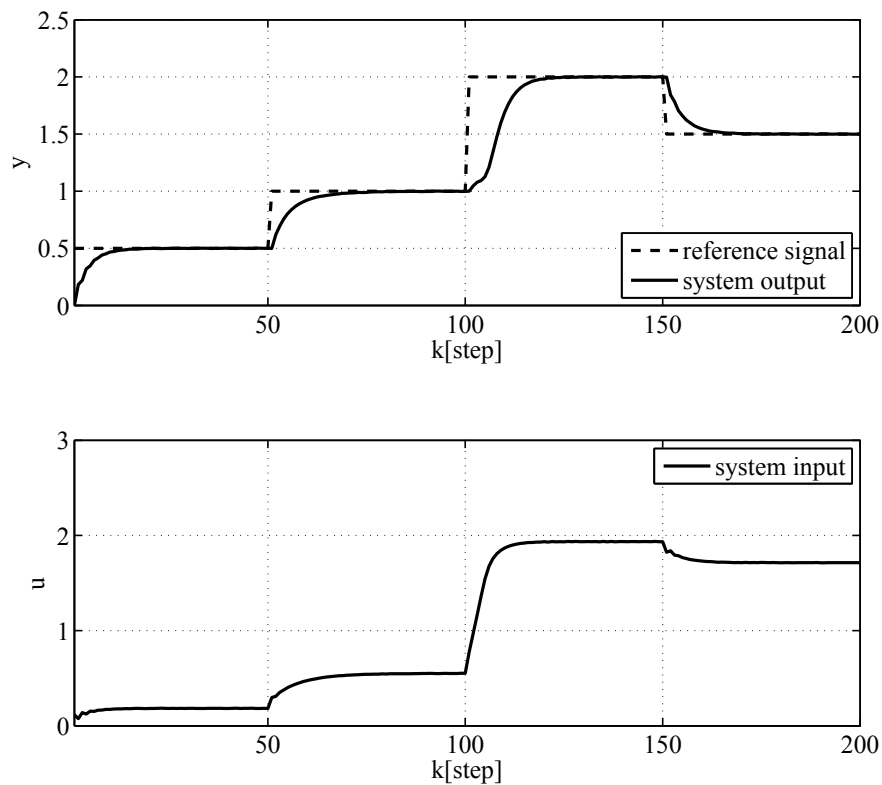

Fig. 4.8: Control result by using the fixed PID controller for Hammerstein model 1

The reference model was designed for the proposed scheme. The user-specified parameters

were $\sigma = 2.0$ [s], $\delta = 0.0$, and $T_s = 1.0$ [s], and the following equation was obtained:

$$G_m(z^{-1}) = \frac{0.34z^{-1}}{1 - 0.74z^{-1} + 0.13z^{-2}}. \quad (4.27)$$

The parameters for the data-driven approach were taken from Table 4.1.

Table 4.1: The user-specified parameters of proposed scheme for Hammerstein model 1

Number of neighbors	$M = 10$
Learning rates	$\eta_P = 0.2$
	$\eta_I = 0.1$
	$\eta_D = 0.2$
Coefficients to inhibit the data	$\alpha_1 = 0.2$
	$\alpha_2 = 0.1$
End condition of learning	$ISE \leq 0.3$

Figs. 4.9 and 4.10 show the control results and the corresponding variation in the PID gains. With the proposed scheme, the system output converged to the reference model output. The PID gains changed with system properties because they were computed using the database, which contained system information. Thus, if any system has a dead band, the desired output can be obtained at all times.

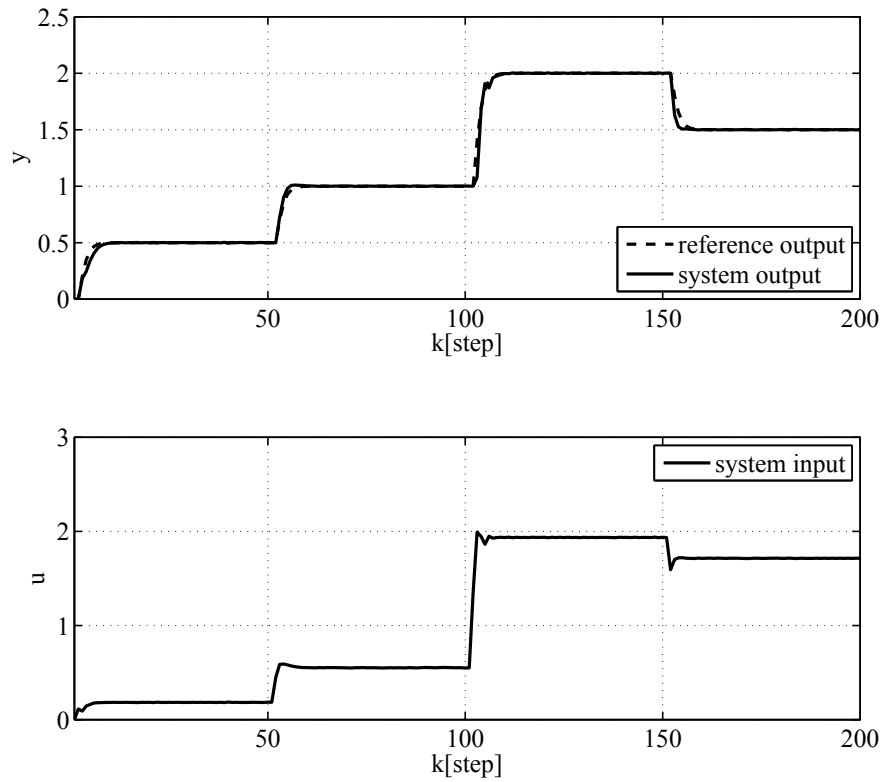

Fig. 4.9: Control result by using proposed scheme for Hammerstein model 1.

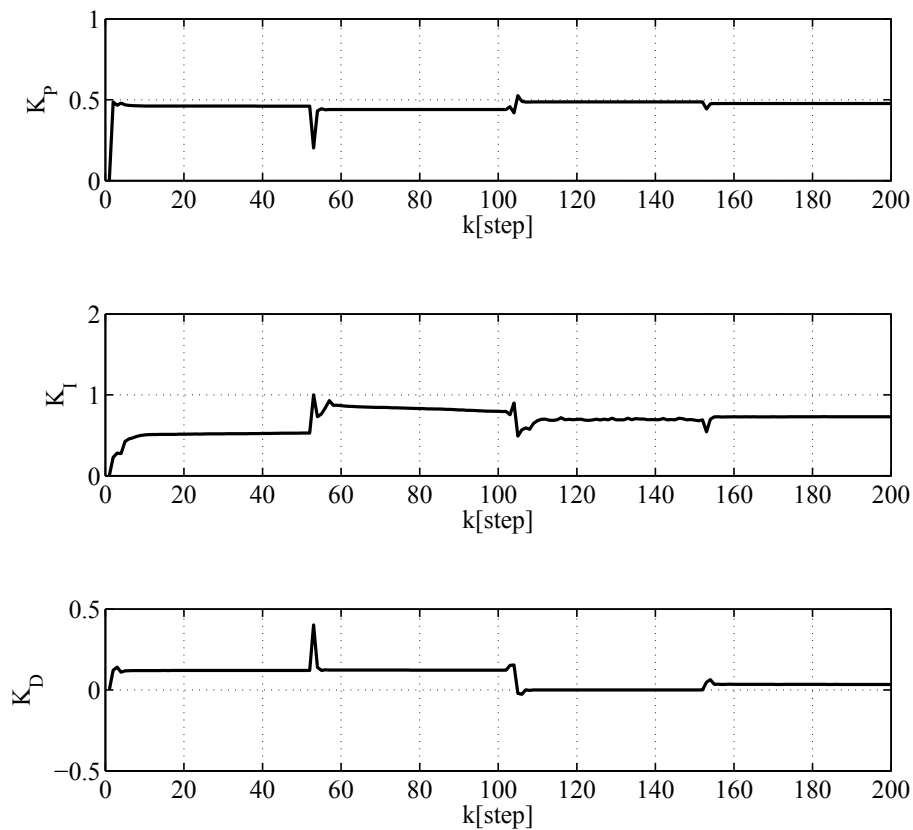

Fig. 4.10: PID gains on Fig. 4.9

4.3.2 Hammerstein Model 2

Next, another Hammerstein model⁽⁹²⁾ was considered using the following equation:

$$\left. \begin{aligned} y(k) &= 0.6y(k-1) - 0.1y(k-2) + 1.2x(k-1) - 0.1x(k-2) + \xi(k) \\ x(k) &= 1.0u(k) - 1.0u^2(k) + 1.0u^3(k) \end{aligned} \right\} \quad (4.28)$$

where $\xi(k)$ denotes the white Gaussian noise with a zero mean and a variance of 0.01^2 . The static characteristics are shown in Fig. 4.11; the system is clearly nonlinear.

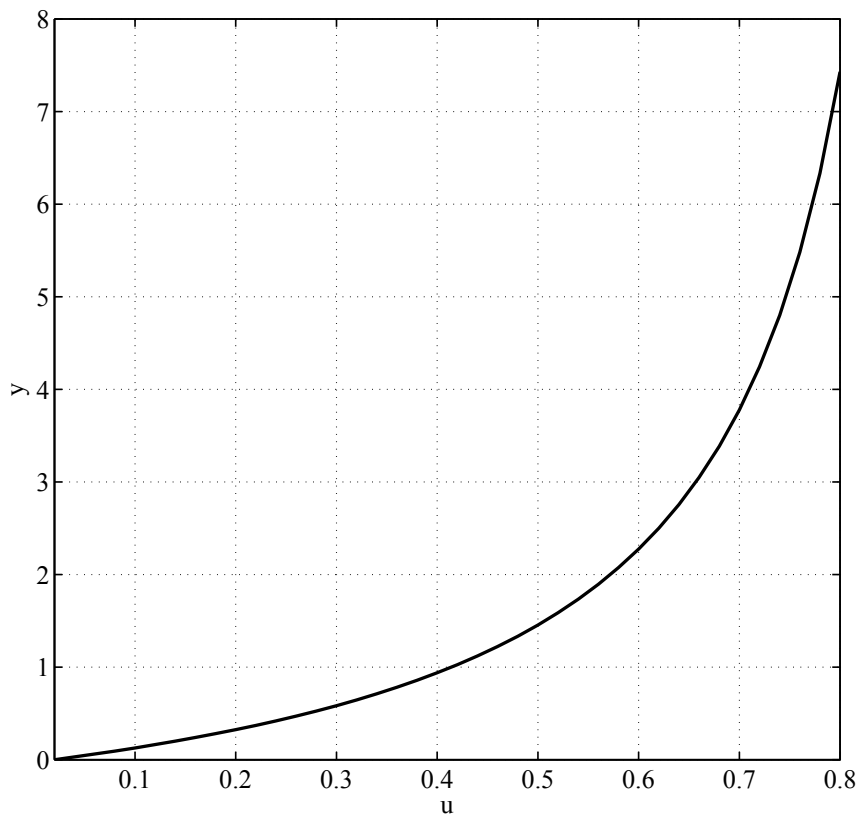

Fig. 4.11: The static characteristics of Hammerstein model 2.

To obtain operating data, a PID control scheme was applied with fixed PID gains.

$$K_P = 0.286, K_I = 0.227, K_D = 0.050. \quad (4.29)$$

These PID gains were determined by the the CHR method and the operating data were obtained.

The reference signals are given by

$$r(k) = \begin{cases} 1.0 & (0 < k \leq 50) \\ 1.5 & (50 < k \leq 100) \\ 3.0 & (100 < k \leq 150) \\ 2.0 & (150 < k \leq 200). \end{cases} \quad (4.30)$$

The result is shown in Fig. 4.12. When fixed PID gains were applied, the system output became

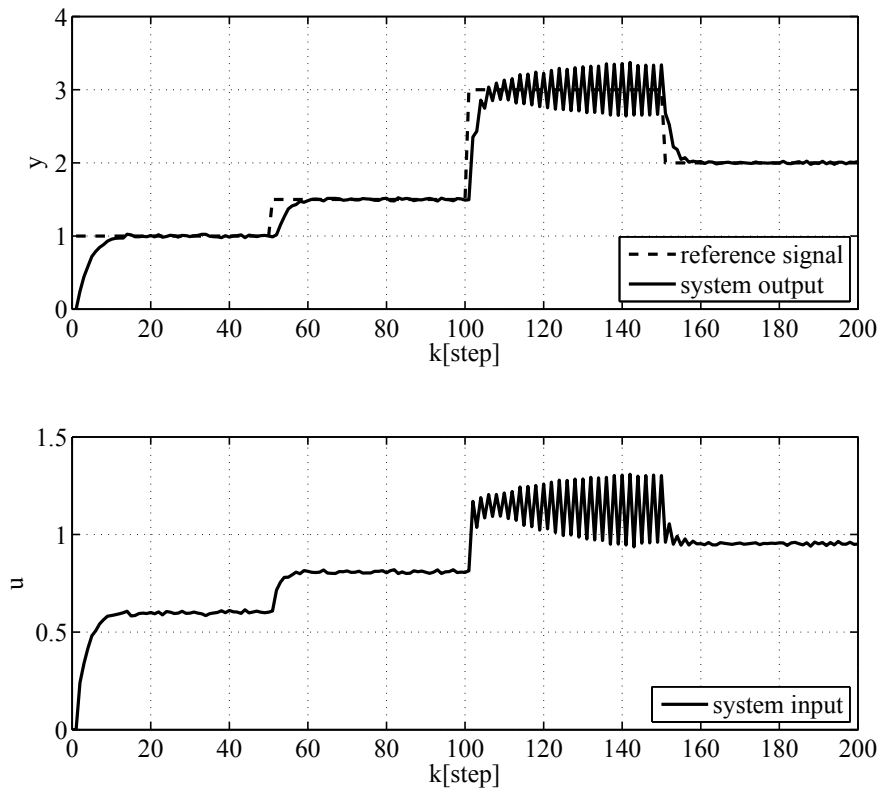

Fig. 4.12: Control result using the fixed PID gains for Hammerstein model 2.

oscillatory for $y > 2.0$ because of nonlinearities.

The proposed scheme was applied to the system, and the obtained control results were used as operating data. The reference model was given by $\sigma = 2.0$ [s], $\delta = 0.0$, and $T_s = 1.0$ [s], and the following equation was used for the design:

$$G_m(z^{-1}) = \frac{0.34z^{-1}}{1 - 0.74z^{-1} + 0.13z^{-2}}. \quad (4.31)$$

Table 4.2 shows the user-specified parameters of the proposed scheme.

Fig. 4.13 shows the control results from using the proposed scheme. A comparison of these results showed that the proposed scheme converge to around the reference model output without oscillation.

Fig. 4.14 shows the calculated PID gains, which varied depending on the changes in the reference signal.

Table 4.2: The user-specified parameters of proposed scheme for Hammerstein model 2

Number of neighbors	$M = 20$
Learning rates	$\eta_P = 0.1$
	$\eta_I = 0.1$
	$\eta_D = 0.1$
Coefficients to inhibit the data	$\alpha_1 = 0.5$
	$\alpha_2 = 0.1$
End condition of learning	$ISE \leq 0.5$

Fig. 4.15 shows the control results from using the proposed scheme for linear systems. The calculated PID gains were as follows:

$$K_P = 0.216, K_I = 0.239, K_D = 0.058. \quad (4.32)$$

The conventional scheme can also compute PID gains directly using operating data. However, the PID gains are fixed. Thus, as shown in Fig. 4.15, the scheme does not always work well for nonlinear systems because the fixed PID gains are adjusted around an equilibrium point. In contrast, the proposed scheme can calculate the varied PID gains in tune with system properties.

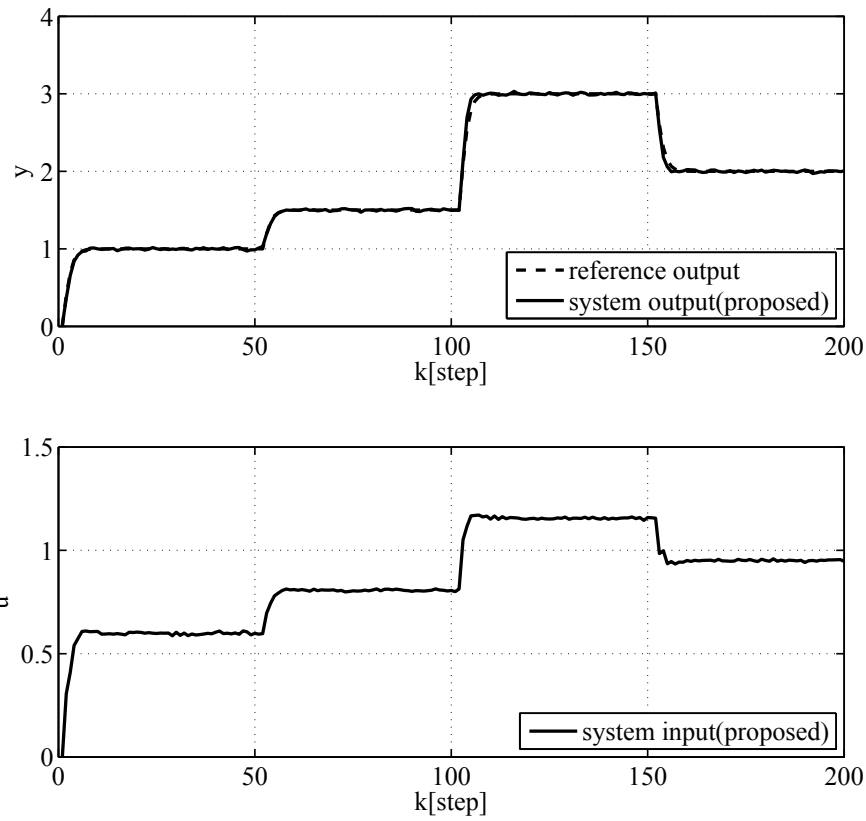

Fig. 4.13: Control result by using proposed scheme for Hammerstein model 2.

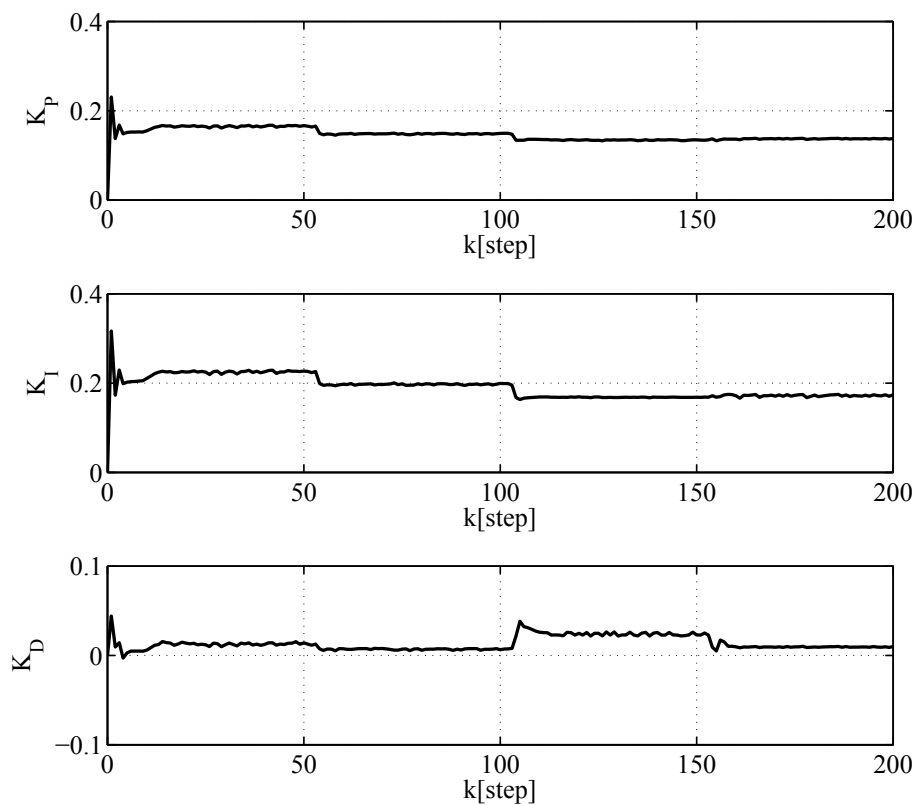

Fig. 4.14: PID gains on Fig. 4.13

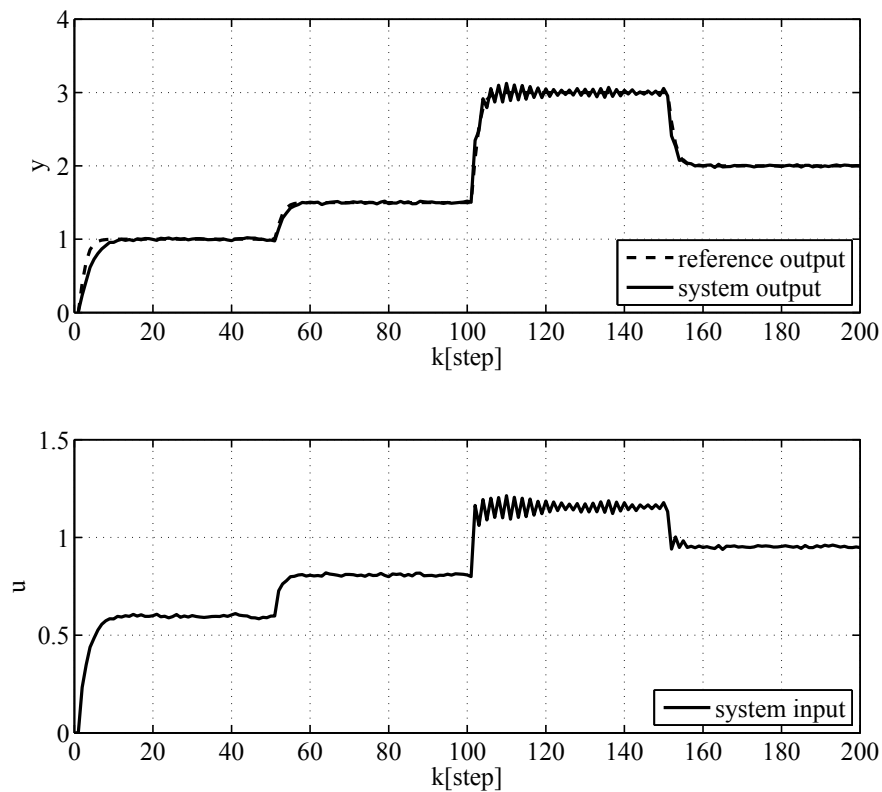

Fig. 4.15: Control result where fixed PID gains by using the conventional data-oriented scheme for Hammerstein model 2.

4.3.3 Hysteresis model

A system with hysteresis⁽³⁸⁾ was considered and is given by the following equation:

$$y(k+1) = \frac{y(k)y(k-1)[y(k)+2.5]}{1+y^2(k)+y^2(k-1)} + u(k) + \xi(k) \quad (4.33)$$

is considered. Here, $\xi(k)$ denotes Gaussian white noise with zero mean and a variance of 0.01^2 . The static property of this system is shown in Fig. 4.16; this system clearly has strong nonlinearities. The system also has hysteresis characteristics between $y = 0.0$ and $y = 2.0$. The

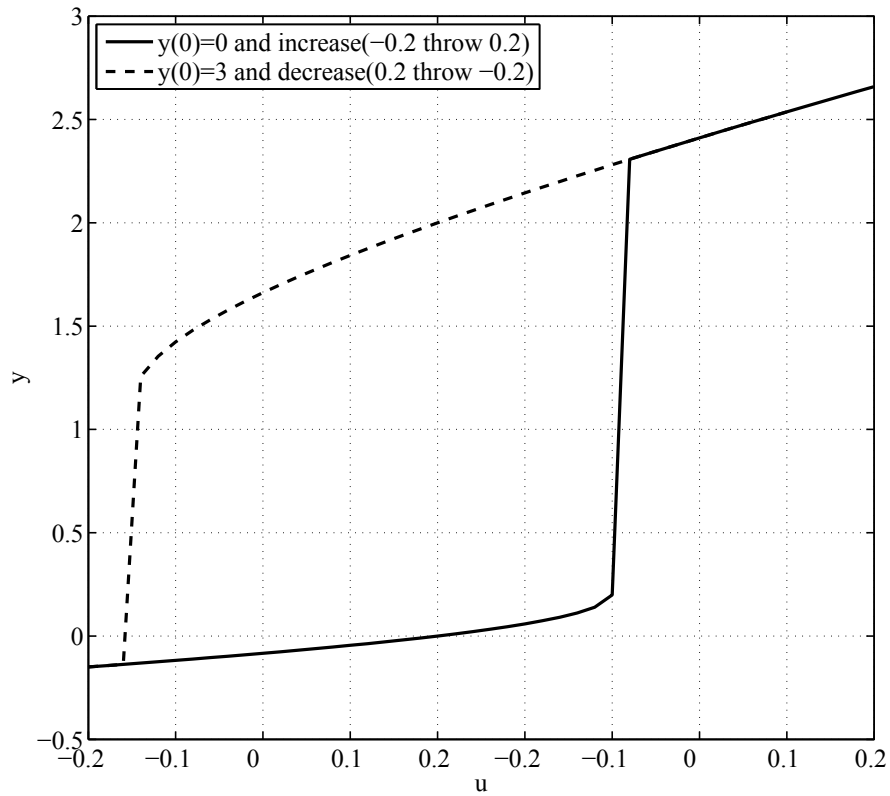

Fig. 4.16: The static characteristics of the hysteresis model.

reference signal is given as follows:

$$r(k) = \begin{cases} 1.5 & (0 < k \leq 100) \\ 0.8 & (100 < k \leq 200) \\ 2.5 & (200 < k \leq 300) \\ -1.0 & (300 < k \leq 400) \end{cases} \quad (4.34)$$

The following set of PID gains was applied to obtain operating data:

$$K_P = 0.654, K_I = 0.208, K_D = 0.187 \quad (4.35)$$

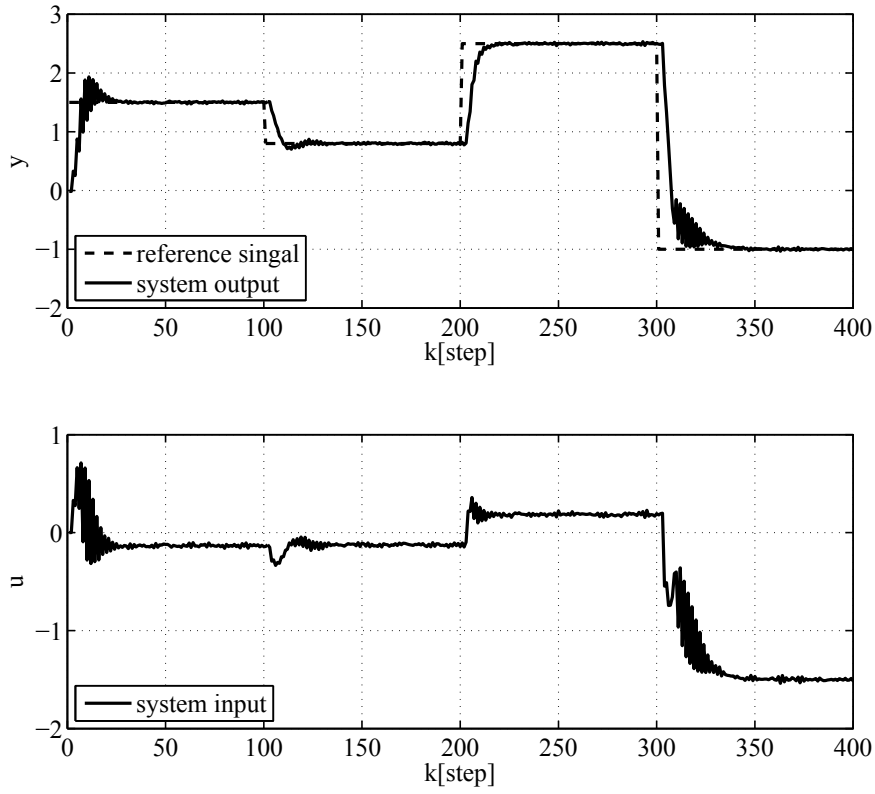

Fig. 4.17: Control result using the fixed PID controller for the hysteresis model.

Because of the nonlinearities, the resulting system oscillated around $y = 0.0$ and $k = 350$.

The proposed scheme was applied to the hysteresis model using the operating data. The desired reference model was designed for $\sigma = 5.0$ [s], $\delta = 0.0$, and $T_s = 1.0$ [s]. The following equation was obtained:

$$G(z^{-1}) = \frac{0.11z^{-1}}{1 - 1.34z^{-1} + 0.45z^{-2}}. \quad (4.36)$$

Table 4.3 shows the user-specified parameters.

Figs. 4.18 and 4.19 show the control results and the PID gains using the proposed scheme, respectively. Fig. 4.18 clearly shows that the system output converged to the reference value, and oscillation was expected.

Table 4.3: The user-specified parameters of proposed scheme for the hysteresis model.

Number of neighbors	$M = 30$
Learning rates	$\eta_P = 0.05$
	$\eta_I = 0.05$
	$\eta_D = 0.05$
Coefficients to inhibit the data	$\alpha_1 = 0.5$
	$\alpha_2 = 0.1$
End condition of learning	$ISE \leq 0.5$

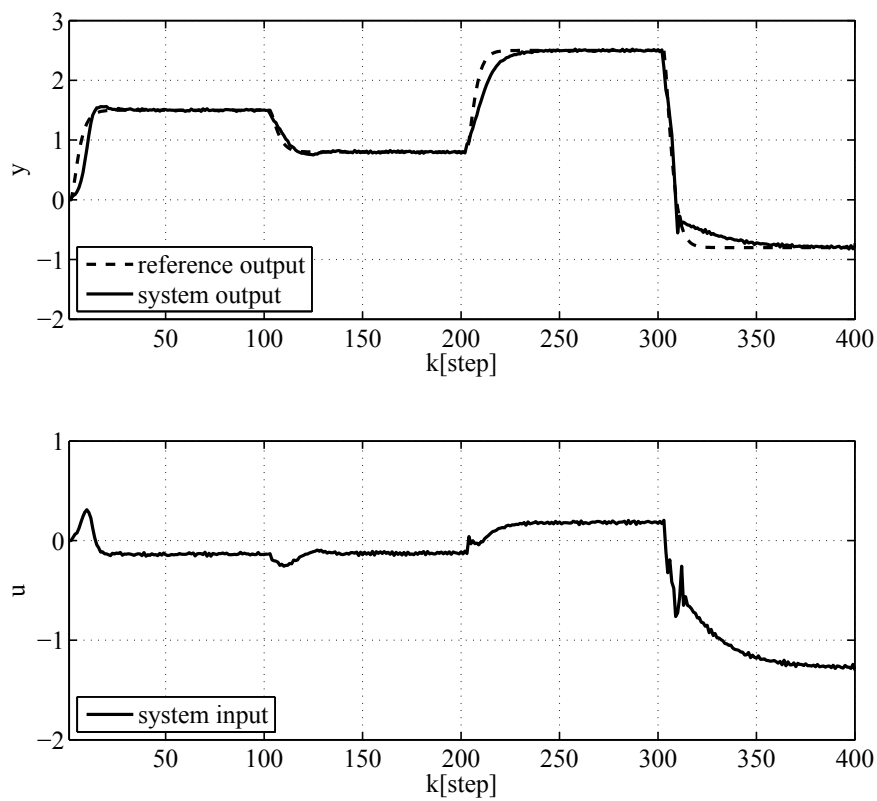

Fig. 4.18: Control result using the proposed scheme for the hysteresis model

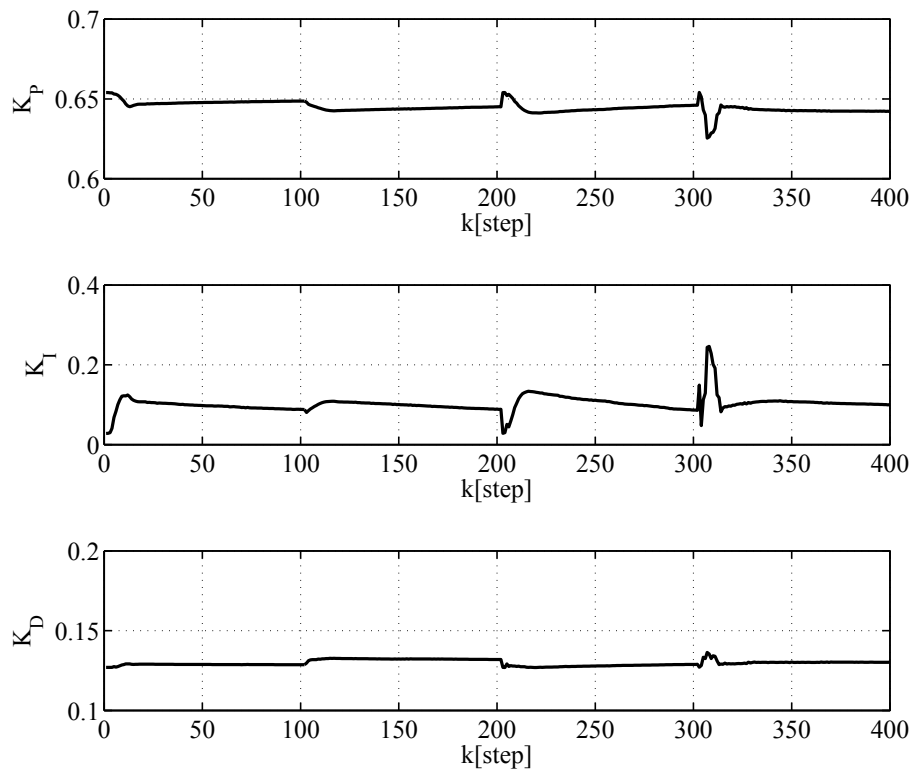

Fig. 4.19: PID gains on Fig. 4.18

4.4 Conclusions

This chapter has presented the proposed data-oriented nonlinear PID control system. The proposed scheme has been applied to numerical simulation examples to demonstrate its effectiveness.

The proposed scheme fuses two ideas: the data-driven PID control scheme and the previous proposed scheme for nonlinear systems. The proposed scheme has the following features:

- PID gains can be automatically calculated in tune with system properties. PID gains are determined based on the database, and the desired control result is always obtained.
- The database is constructed in an offline manner. Experiments do not need to be performed several times to build up the database. Thus, the computational burden can be reduced.

Chapter 5

Conclusions

This dissertation has presented data-oriented control systems which were designed by using operating data based on minimizing the generalized output errors. The generalized output is developed from a PID control law which is widely applied in industrial processes.

Chapter 2 has presented the proposed scheme for single-input/single-output linear systems. The proposed scheme can obtain PID gains without the description model. The output signal converges to the desired reference signal as designed by the operator. The effectiveness of the proposed scheme has been numerically verified through two simulation examples. The results have verified that almost the same PID gains can be computed from the input/output data even if the initial PID gains of the operating data are different. The usefulness of this scheme has been demonstrated through application to the injection molding process. The control results have showed good performances for real systems.

Chapter 3 has expanded the scheme to multi-input/multi-output systems. The generalized output is defined to include the PID gain matrix based on the concepts of the proposed scheme in chapter 2. Non-diagonal elements of the PID gain matrix are optimized for decoupling because real MIMO systems have interference for each input and output. The behavior of the proposed scheme has been simulated numerically, and the results have showed that the scheme can reduce the interference.

Chapter 4 has presented the design of a data-oriented control system for nonlinear systems. Most systems have nonlinearities, and obtaining the desired control results when using a fixed PID controller is difficult. The proposed scheme applies the design concept of data-driven

controller systems. The data-driven controller has been proposed for nonlinear systems, and its effectiveness has demonstrated. However, this control scheme, requires a considerable computational burden for online learning to update the database. The online learning limits its implementation in industrial processes. Thus, the proposed scheme is based on the generalized output for the controller design scheme so that the database can be updated in an offline manner. The proposed scheme has been applied to some numerical examples to illustrate its effectiveness. The proposed scheme has been always able to obtain the desired output because the PID gains can be changed with the system properties.

When the characteristics of the system are changed, the operating conditions and materials changes as well. The operating data needs to be reacquired to rebuild the database, however, it is inefficient. As a solution, the proposed scheme suggests constructing the database for the system in an offline manner. The control performance should be evaluated; the database updates according to the system properties while the system is running.

Thus, the proposed scheme needs to introduce performance-driven control methods⁽⁹³⁾. Research on control performance is actively on-going in order to maintain the overall stability of the system and identify degraded loops^(94–100). Performance-driven control methods are one research topic where integrates "evaluation" and "design". Operators can easily tune system parameters to achieve the desired control performance. Thus, the desired response can always be obtained even if the system characteristics are changed by various factors. A one-parameter tuning PID controller⁽¹⁰¹⁾ can adjust the PID parameters using one parameter, if a control performance is degraded. The effectiveness of the controller has been demonstrated in real systems^(102,103).

This proposed scheme uses a generalized output which is derived from the PID control law for the control system. The PID controller has been used in many industrial processes because of its simplicity and is pivotal to design based on the generalized output error. There are many difficulties with adapting it to new field of technology because operators need to get used to it and understand it. Moreover, the system may need to be rebuilt to do so. However, in that regard, a scheme that can be construct a PID control system is practical. The validity of the PID gains can evaluate by operator's experience. Even when the PID gains are adjusted to obtain better performance, this approach is helpful. As shown in the numerical examples,

the difference between good and bad control results does not depend on the input and output results. Therefore, the operator can adjust the control performance by using the proposed scheme.

Finally, the outlook for the future in control is discussed. PID control is the most common control system in industrial fields, however sometimes it is insufficient to obtain a high-precision control performance. For example, a system with a large time delay can not be controlled easily, *e.g.* an L/T of more than 0.5. Therefore, the structure and function of the controller need to suit the system without the structure of the controller being limited. In this proposed scheme, the generalized output is defined so that the reference signal of the controller is equivalent to other components of the controller. Furthermore, the parameters are optimized so that the error between the signal passed to the reference model and the output of the operating data (*i.e.* the generalized output error) is zero. This concept was verified to be effective for not only the PID controller but also a model-based control system. That is, compensating elements after the removal of a reference signal element are automatically constructed as the generalized output, and these parameters are optimized. Thus, the controller can be designed to follow the desired reference model output alone without control specifications and operating data. This is called a universal controller. Future research will involve the design and industrial development of a universal controller.

References

- [1] N.Suda : PID Control (Japanese), *Asakura Publishing Co.*, 1992.
- [2] S.Yamamoto and N.Kato : Fundamentals and Applications of PID control (Japanese), *Asakura Publishing*, 2005.
- [3] M.Kano, M.Ogawa : Practice and Challenges in Chemical Process Control Applications in Japan, *Proc. of IFAC World Congress*, pp.10608–10613, 2008.
- [4] J.A.Miller, A.M.Lopez, C.L.Smith and P.W.Murrill : A Comparison of Controller Tuning Techniques, *Control Engineering*, Vol.14, pp.72–75, 1967.
- [5] G.H.Cohn and G.A.Coon : Theoretical Consideration of Retarded Control, *Transactions of American Society of Mechanical Engineering*, No.75, pp.827–834, 1953.
- [6] T.Kitamori : Design of the control system based on partial knowledge of the controlled object (Japanese), *Transactions of the Society of Instrument and Control Engineers*, Vol.15, No.4, pp.549–555, 1992.
- [7] K.J.Astrom and T.Hagglund : Advanced PID Control. *ISA Book*, 2005. F
- [8] K.Takao, K.Nakano, T.Yamamoto and T.Hinamoto: A Design of PID Controllers with a Switching Structure by a Support Vector Machine, *Journal of the Institute of Systems, Control and Information Engineer*, Vol.19, No.11, pp.435–442, 2006.
- [9] T.Yamamoto, M.Mitsukura, M.Kaneda and K.Fuji : A Genetic Tuning Algorithm of PID Parameters and Its Application for a Chemical Process (Japanese), *FAN Symposium : fuzzy, artificial intelligence, neural networks and computational intelligence 7*, pp.621–624, 1997.

- [10] J.G.Ziegler, N.B.Nichols : Optimum settings for Automatic controllers, *Trans. ASME*, Vol.64, No.8, pp.759–768, 1942.
- [11] K.L.Chien, J.A.Hrones, and J.B.Reswick : On the automatic control of generalized passive systems, *Trans. ASME*, Vol.74, pp.175–185, 1972.
- [12] M.Nakamoto : Direct PID Parameter Tuning Method Using Experimental Data(;Special Issue;Parameters Tuning in PID Control) (Japanese), *Journal of the Institute of Systems, Control and Information Engineers*, Vol.50, No.12, pp.447–452, 2006.
- [13] O.Kaneko : Parameter Tuning of a Controller Based on the Direct Use of the Data (Japanese), *Journal of the Society of Instrument and Control Engineers*, Vol.47, No.11, pp.903–908, 2008.
- [14] A.Stenman, F .Gustafsson and L.Ljung : Just in time models for dynamical systems, *35th IEEE Conference on Decision and Control*, pp.1115–1120, 1996.
- [15] Q.Zheng : Just-In-Time Modeling for Functin Prediction and its Applications, *Asian. J. Control*, Vol.3, No.1, pp.35–44, 1999.
- [16] H.Hjalmarsson, M.Gevers, S.Gunnarsson and O.Lequin : Iterative Feedback Tuning : Theory and Applications, *IEEE control system Magazines*, Vol.18, pp.26–41, 1998.
- [17] K.Hamamoto : Iterative feedback tuning of controllers for a two-mass-spring system, *Control Engineering Practice*, Vol.11, pp.1061–1068, 2003.
- [18] M.Nakamoto : An Application of Iterative Feedback Tuning for a Process Control (Japanese), *Transactions of the Society of Instrument and Control Engineers*, Vol.39, No.10, pp.924–932, 2003.
- [19] G.O.Guardabassi : Virtual reference direct design method : An off-line approach to data-based control system design, *IEEE Trans. on Automation Control*. Vol.45, pp.954-959, 2000.
- [20] M.C.Canpi, A.Lecchini and S.M.Savaresi : Virtual Reference Feedback Turning : A Direct Method for the Disign of Feed back Controllers, *Automatica*, Vol.38, pp.1337–1346, 2002.

- [21] M.Nakamoto : An Application of the Virtual Reference Feedback Tuning Method for Multivariable Process Control (Japanese), *Transactions of the Society of Instrument and Control Engineers*, Vol.41, No.4, pp.330–337, 2005.
- [22] O.Kaneko, K.Yoshida, K.Matsumoto and T.Fujii : A New Parameter Tuning for Controllers Based on Least-Squares Method by using One-Shot Closed Loop Experimental Data : An Extension of Fictitious Reference Iterative Tuning (Japanese), *Systems, control and information Institute of Systems*, Vol.18, No.11, pp.400–409, 2005.
- [23] O.Kaneko, M.Miyaji and T.Fuji : Notes on the Optimality of the Fictitious Reference Iterative Tuning (Japanese), *Transactions of the Society of Instrument and Control Engineers*, Vol.44, No.6, pp.541–543, 2008.
- [24] O.Kaneko : On Basics and Future Developments of FRIT From Viewpoints of Tacking for Desired Responses (Japanese), *The transactions of the Institute of Electrical Engineers of Japan. C, A publication of Electronics, Information and Systems Society*, Vol.132, No.6, pp.816–819, 2012.
- [25] T.Takagi and I.Mizumoto : PFC Design via FRIT with T-S Fuzzy Like Model for Discrete-Time Adaptive Control Systems (Japanese), *The transactions of the Institute of Electrical Engineers of Japan. C, A publication of Electronics, Information and System Society*, Vol.133, No.6, pp.1120–1128, 2013.
- [26] H.Nakatsuka, T.Sato and T.Yamamoto : Feedforward Controller Tuning Method based on Online FRIT with Control Performance Evaluation (Japanese), *Transactions of the Institute of Systems, Control and Information Engineers*, Vol.26, No.6, pp.221–223, 2013.
- [27] S.Masuda and G.Li: An FRIT method for disturbance attenuation using input-output data for disturbance responses, *Proceeding of IFAC Workshop on Adaptation and Learning in Control and Signal Processing*, Antalya, 2010.
- [28] S.Masuda : A Fictitious Reference Iterative Tuning Method with Simultaneous Delay Parameter Tuning of the Reference Model, *International Jouranl of Innovative Computing, Information and Control*, Vol.6, No.8, pp.1–13, 2010.

- [29] S.Masuda : PID Gain Tuning for Disturbance Attenuation FRIT Method (Japanese), *The transactions of the Institute of Electrical Engineers of Japan. C, A publication of Electronics, Information and Systems Society*, Vol.132, No.6, pp.820–823, 2012.
- [30] O.Kaneko, M.Miyaji, S.Magota and T.Fuji, et al : An Identification Based on Fictitious Reference Iterative Tuning within the One-Degree of Freedom Control Scheme and Its Application to the Identification of the Opening-and-Closing Speed Dynamics of the Door of an Elevator (Japanese), *Transactions of the Society of Instrument and Control Engineers*, Vol.20, No.11, pp.439–447, 2007.
- [31] Y.Wakasa, S.Kanagawa and K.Tanaka : A Controller Parameter Tuning Method Considering Dead-Zone and Saturation and its Application to Ultrasonic Motors, *ICIC express letters. an international journal of research and surveys. Part B, Applications*, Vol.3, No.2, pp.265–270, 2012.
- [32] Y.Matsui, S.Akamatsu and T.Kimura, et al : An Application of Fictitious Reference Iterative Tuning to State Feedback Control (Japanese), *The Transactions of the Institute of Electrical Engineers of Japan. C, A publication of Electronics, Information and Systems Society*, Vol.132, No.6, pp.851–859, 2012.
- [33] K.Tasaka : Direct PID Tuning from Closed-Loop Data and Its Application to Unstable Processes, *Transactions Institute of Systems. Control and Information Engineers*, No. 22, Vol.4, pp.137–144, 2009.
- [34] O.Kaneko, Y.Wadagaki and S.Yamamoto : Simultaneous Attainment of the Optimal Parameter of a Controller and a Mathematical Model by an Application of the FRIT for the Smith Compensator (Japanese), *The Transactions of the Institute of Electrical Engineers of Japan. C, A publication of Electronics, Information and System Society*, Vol.131, No.4, pp.742–750, 2011.
- [35] M.Kano, M.Ogawa and K.Takasa, et al : Development and practical application of the model unnecessary PID tuning method E-FRIT (Japanese), *Journal of the Society of Instrument and Control Engineers*, Vol.50, No.12, pp.1076–1079, 2011.

- [36] M.Kano : Practical Use of Operation Data in the Process Industry (Japanese), *The Transactions of the Institute of Electrical Engineers of Japan. C, A publication of Electronics, Information and System Society*, Vol.131, No.4, pp.710–717, 2011.
- [37] T.Kitamori : Principle, Synthesis and Design of I-PD Control (Japanese), *Journal of the Institute of Systems, Control and Information Engineer*, Vol.42, No.1, pp.7–17, 1998.
- [38] K.S.Narendra and K.Parthasarathy : Identification and control of dynamical systems using neural networks, *IEEE Transactions. Neural Network*, Vol.1, No.1, pp.4–27, 1990.
- [39] A.Sakaguchi and T.Yamamoto : A Design of Generalized Minimum Variance Controllers Using a GMDH Network for Nonlinear Systems, *IEICE Transactions on fundamentals of electronics, communications and computer sciences*, Vol.E84-A, No.11, pp.2901–2907, 2001.
- [40] K.Uosaki and T.Hatanaka : Identification for Nonlinear Systems using Genetic Programming (Japanese), *Transactions of the Society of Instrument and Control Engineers*, Vol.39, No.5, 2000.
- [41] R.Leardi, R. Boggia and M.Terrile : Genetic algorithms as a strategy for feature selection, *Journal of Chemometr*, Vol.6, pp.267–281, 1992.
- [42] G.Qingzhi and T.Asakura : Identification of Nonlinear Time lag System by Genetic Algorithm, *IEICE technical report. Nonlinear problems*, Vol.96, No.569, pp.33–38, 1997.
- [43] U.Sermsak and N.Fujii : Application of Genetic Programming to System Modeling from Input-Output Data, *IEICE transactions on fundamentals of electronics, communications and computer sciences*, Vol.E81-A, No.5, pp.924–930, 1998.
- [44] Y.Mitsukura, M.Fukumi and T.Yamamoto : A System Identification Method Using a Hybrid-Type Genetic Algorithm, *FAN Symposium : Intelligent System Symposium-fuzzy, AI, neural network applications technologies*, Vol.12, pp.451–452, 2002.
- [45] T.Hachino and H.Takaka : On-line Identification Method of Continuous-Time Nonlinear Systems Using Radial Basis Function Network Model Adjusted by Genetic, *IEICE trans-*

- actions on fundamentals of electronics, communications and computer sciences*, Vol.E87-A, No.9, pp.2372–2378, 2004.
- [46] T.Hachino, H.Takaka, Structure Selection and Identification of Hammerstein Type Non-linear Systems Using Automatic Choosing Function Model and Genetic Algorithm, *IEICE transactions on fundamentals of electronics, communications and computer sciences*, Vol.E88-A, No.10, pp.2541–2547, 2005.
- [47] A.Sakaguchi and T.Yamamoto, A Structure Design Scheme of GMDH Network Using GA (Japanese), *Intelligent System Symposium*, Vol.12, pp.449–450, 2002.
- [48] D.Rumelhart and McClelland : Parallel Distributed Processing: Explorations in the Microstructure of Cognition, *MIT Press*, 1986.
- [49] A.G.Ivakhnenko : Heuristic self-organization in problems of engineering cybernetics, *Automatica*, Vol.6, No.2, pp.207–219, 1970.
- [50] S.Adachi : Basic System Identification (Japanese), *Tokyo Denki University Press*, 2009.
- [51] K.Akiduki and I.Hanazaki : System modeling and identification (Japanese), *The transactions of the Institute of Electrical Engineers of Japan. C, A publication of Electronics, Information and System Society*, Vol.115, No.7, pp.855–859, 1995.
- [52] S.Adachi : System Identification for Control Using MATLAB (Japanese), *Tokyo Denki University Press*, 1996.
- [53] T.Yamamoto and S.L.Shah: Design and Experimental Evaluation of a Multivariable Self-Tuning PID Controller, *IEEE Proc. of Control Theory and Applications*, Vol.151, No.5, pp.645–652, 2004.
- [54] D.E.Goldberg : Genetic algorithms and machine learning, *Addison-Wesley Professional*, 1989.
- [55] H.Kitano : Genetic Algorithm (Japanese), *Industrial Library Publishing*, 1993.
- [56] I.Kumano : Learning and Neural Network (Japanese), *Kitamori Publishing*, 1998.

- [57] B.Porter and A.H.Jones : Genetic tuning of digital PID controllers, *Electronics Letter*, Vol.28, pp.843–844, 1992.
- [58] T.Yamamoto, Y.Mitsukura and M.Kaneda : A Design of PID Controllers Using a Genetic Algorithm, *Transactions of the Society of Instrument and Control Engineers*, Vol.35, No.4, pp.531–537, 1999.
- [59] T.K.Kiong, W.Q.Guo, H.C.Chieh and T.J.Hagglund : Advances in PID Control, *Springer*, 2000.
- [60] T.Yamamoto : New development of self-tuning controller - generalized minimum variance control and PID control- (Japanese), *Transactions of the Society of Instrument and Control Engineers*, Vol.40, pp.704–710, 2001.
- [61] E.J.Davison : On Pole assignment in Multivariable Linear Systems, *IEEE Transactions on Automatic Control*, Vol.AC-13, No.6, pp.747–748, 1968.
- [62] H.Hikita : A New Design Method Realizing Decoupling and Arbitrary Pole Assignment in Linear Systems, *Transactions of the Japan Society of Mechanical Engineers, Series.C*, Vol.52, No.476, pp.1355–1361, 1986.
- [63] P.E.Wellstead : Pole assignment self-tuning regulator, *IEEE Proceeding. D*, Vol.126, No.8, pp.781–787, 1979.
- [64] Y.Muto and T.Hara : A Design Method of Pole Placement and Observer for Non-Lexicographically-Fixed Linear Time-Varying Discrete MIMO Systems, *IEEJ Transactions on Electronics, Information and Systems*, Vol.133, No.2, pp.365–372, 2013
- [65] M.Sasaki and M.Miyazaki : Compensator Design for PID Control of MIMO Systems by using Real Code Genetic Algorithm (Japanese), *Kanto Gakuin University College of Engineering Report*, Vol.55, No.2, pp.93–100, 2012.
- [66] H.H.Lee, M.Nagamachi, W.K.Choi, and J.Y.Song, et al : Multi-Stage Noninteracting PID Control by Precompensators with Series-Parallel Connection, *The Transactions of the Institute of Electrical Engineers of Japan. C, A publication of Electronics, Information and System Society*, Vol.123, Vol.1, pp.43–49, 2003.

- [67] T.Yamamoto and S.L.Shah:A Design Scheme of Multivariable Self-Tuning PID Controllers, *Proc. of 2nd Asian Control Conference*, Seoul, pp.157–160, 1997.
- [68] E.F.Camacho and C.Bordon : Model predictive control in the process industry, *Springer-Verlag*, pp.113–114, 1995.
- [69] M.Katayama, T.Yamamoto and Y.Mada : A Practical Design Scheme of Multiloop Robust PID Control Systems, *The transactions of the Institute of Electrical Engineers of Japan. C, A publication of Electronics, Information and System Society*, Vol.123, No.2, pp.330–337, 2003.
- [70] M.Asano and T.Yamamoto : A Design of Self-Tuning Predictive PID Controllers, *IE-ICE transactions on fundamentals of electronics, communications and computer sciences*, Vol.E84-A, No.7, pp.1779–1783, 2001.
- [71] S.Imai and T.Yamamoto : Design of a Self-Tuning Controller using Multiple Local Linear Models for Nonlinear Systems (Japanese), *The Transactions of the Institute of Electrical Engineers of Japan. C, A publication of Electronics, Information and Systems Society*, Vol.132, No.6, pp.860–865, 2012.
- [72] K.J.Astrom : Theory and applications of self-tuning regulators, *Automatica*, Vol.13, No.5, pp.457–476, 1977.
- [73] D.W.Clarke : Self-tuning control, *Proceeding. IEEE*, Vol.126D, No.6, pp.633–640, 1979.
- [74] F.Cameron : A self-tuning controller with a PID structure, *Int. Journal of Control*, Vol.38, pp.401–417, 1983.
- [75] T.Yamamoto : A Self-Tuning PID Controller and Its Application for a Chemical Process , *Proceeding IEEE Int. Conference. on Emerging Technologies and Factory Automation*, 1996.
- [76] T.Yamamoto and M.Kaneda : A Design of Self-Tuning PID Controllers Based on the Generalized Minimum Variance Control Law (Japanese), *Journal of the Institute of Systems, Control and Information Engineers*, Vol.11, No.1, pp.1–9, 1998.

- [77] T.Oki, T.Yamamoto, M.Kaneda, and S.Omatsu : A Design Method of Self-Tuning PID Control System by using Multiple Models, *FAN Symposium : fuzzy, artificial intelligence, neural networks and computational intelligence*, Vol.7, pp.205–210, 1997.
- [78] M.Tokuda, T.Yamamoto and Y.Monden : A Design of Neural-Net Based Decouplers (Japanese), *The transactions of the Institute of Electrical Engineers of Japan. C, A publication of Electronics, Information and System Society*, Vol.125, No.4, pp.591–599, 2005.
- [79] T.Yamamoto, K.Takao and T.Yamada : Design of a Data-Driven PID Controller, *IEEE Trans. Control Systems Technology*, Vol.17, No.1, pp.29–39, 2009.
- [80] M.W.Braun : A 'Model-on-Demand' identification methodology for non-linear process systems, *Int. Journal of Control*, Vol.74, No.18, pp.1708–1717, 2001.
- [81] G.J.Jeon : Neural Network Indirect Adaptive Control with Fast Learning Algorithm, *Neurocomputing*, Vol.13, pp.185–199, 1996.
- [82] D.A.Linkens : Learning systems in intelligent control : an appraisal of fuzzy, neural and genetic control applications, *IEE Proceedings of Control Theory and Applications*, Vol.143, No.4, pp.367–386, 1996.
- [83] Yeo.Y : A Neural PID Controller for the pH Neutralization Process, *Industrial Engineering Chemical Research*, Vol.38, 978-987, 1999.
- [84] T.Yamamoto : Adaptive and Learning Control Using Neural Networks(¡Special Feature¡Intelligent Systems Science Approach to Control Systems Science), *Simulation*, Vol.26, No.1, pp.20–25, 2007.
- [85] Y.Abe, M.Konishi, J.Imai, R.Hasegawa, M.Watanabe and H.Kamijo : Neural Network Based PID Gain Tuning of Chemical Plant Controller, *The transactions of the Institute of Electrical Engineers of Japan. C, A publication of Electronics, Information and System Society* Vol.128, No.7, pp.940–947, 2008 (Japanese).
- [86] F.J.Doyle : Nonlinear Model-Based Control Using Second-Order Volterra Models, *Automatica*, Vol.31, pp.697–714, 1995.

- [87] J.Ota and S.Yamamoto : Database-Driven Tuning of PID Controllers (Japanese), *SICE Journal of Control, Measurement, and System Integration*, Vol.40, No.6, pp.664–669, 2004 .
- [88] J.S.Albus, A new approach to manipulator control: Cerebellar model articulation controller, *Transaction of the ASME*, Vol.97, No.3, pp.270–277, 1975.
- [89] T.Yamamoto and M.Kaneda, Intelligent Controller Using CMACs with Self-Organized Structure and Its Application for a Process System, *IEICE Trans. fundamentals*, E82-A, No.5, pp.856–860, 1999.
- [90] R.Kurozumi and T.Yamamoto : A Design of CMAC Based Intelligent PID Controllers, *The transactions of the Institute of Electrical Engineers of Japan. C, A publication of Electronics, Information and System Society*, Vol.125, No.4, pp.607–615, 2005.
- [91] S.Wakitani, Y.Ohnishi and T.Yamamoto : Design of a CMAC-Based PID Controller Using FRIT for Nonlinear Systems, *Transactions of the Society of Instrument and Control Engineers*, Vol.48, No.12, pp.847–853, 2012.
- [92] L.Zi-Qiang: On identification of the controlled plants described by the Hammerstein system, *IEEE Trans. Automation Control*, Vol.AC-39, No.2, pp.569–573, 1994
- [93] B.Huang : Performance Assessment of Control Loops, *Theory and Applications*, 1999.
- [94] T.J.Harris : Assessment of Closed Loop Performance, *J.Canadian J. of Chemical Engineering*, Vol.67, pp.856–861,1989.
- [95] L.D.Desborough and T.J.Harris : Performance Assessment Measures for Univariate Feedback Control, *Canadian J. of Chemical Engineering*, Vol.70, pp.1186–1197,1992.
- [96] B.Huang and S.L.Shah : Performance Assessment of Control Loops, *Theory and Applications*, Springer-Verlag, London, 1999.
- [97] T.J.Harris, C.T.Seppala and L.D.Desborough : A Review of Performance Monitoring and Assessment Techniques for Univariate and Multivariate Control Systems, *J. of Process Control*, Vol.9, pp.1–17, 1999.

- [98] M.J.Grimble : Controller Performance Benchmarking and Tuning using Generalised Minimum Variance Control, *Automatica*, Vol.38, pp.2111–2119, 2002.
- [99] B.Huang : A Pragmatic Approach Towards Assessment of Control Loop Performance, *Int. J. of Adaptive Control and Signal Processing*, Vol.17, pp.589–608, 2003.
- [100] M.Kano and Y.Yamashita : Control Performance Assessment and Monitoring for Process Control Systems, *Journal of the Society of Instrument and Control Engineers*, Vol.44, No.2, pp.125–129, 2005.
- [101] T.Yamamoto : Design of a Performance-Driven PID Controller Via One-Parameter Tuning, *Journal of the Society of Instrument and Control Engineers*, Vol.48, No.8, pp.646–651, 2009.
- [102] K.Fuji and T.Yamamoto : Design of a One-Parameter Tuning PID Controller and Its Application for a Refinery, *Transactions of the Society of Instrument and Control Engineers on Industrial Application*, Vol.7, No.10, pp.67–71, 2008.
- [103] Y.Ohnishi, T.Sato and T.Yamamoto : Design of Performance-Driven PID Control Systems based on Control Performance Assessment, *The transactions of the Institute of Electrical Engineers of Japan. C, A publication of Electronics, Information and Systems Society* Vol.132, No.6, pp.824–827, 2012.

Publications

- [1] K.Hayashi, T.Yamamoto : Evolutionary Design of a PID Controller Using Closed-loop Data: *The transactions of the Institute of Electrical Engineers of Japan. C, A publication of Electronics, Information and System Society*, Vol.131, No.4, pp.794–799, 2011 (Japanese).
- [2] K.Hayashi, T.Yamamoto : Design of a Data-Oriented Multivariable PID Control System : *The transactions of the Institute of Electrical Engineers of Japan. C, A publication of Electronics, Information and System Society*, Vol.133, No.12, pp.2229–2235, 2013 (Japanese).
- [3] K.Hayashi and T.Yamamoto : Design of a Data-Oriented Nonlinear PID Control System, *IEICE Trans. on Fundamentals*, Vol.E97-A, No.2, pp.669-674, 2014.
- [4] K.Hayashi and T.Yamamoto : Closed-Loop Data-Oriented Design of a PID Controller, *Proc. of IIFAC Workshop on Automation in the Mining, Mineral and Metal Industries*, We-AT1.2, Gifu, 2012.