

# Matching Theory to Context: Building a Teacher Training Course for Secondary School Teachers of English in Japan

Takamichi ISODA  
Walter DAVIES  
Kenneth FORDYCE

Institute for Foreign Language Research and Education  
Hiroshima University

In recent years, the Ministry of Education has made attempts to reform the system of English language education in Japan, and these have included a focus on teacher training. This article focuses on the theoretical ideas that were used in the provision of an in-service teacher education course for junior and senior high school teachers of English at Hiroshima University. In this article, we briefly explain the course, examining the institutional changes that led to its creation, general background to changes in English language teaching at secondary schools, and a brief overview of how it was taught. In the main part of the article we describe the theoretical ideas and analyses that were used to build the course, and how they were developed for its three sections. In the discussion, we consider some of the key issues that emerged from the process of planning and teaching the course, and then consider possibilities for the future.

## BACKGROUND

The teacher education course was held as a certified program for renewal of teacher qualification. The Ministry of Education, Culture, Sports, and Science and Technology (MEXT) amended the Act for Enforcement of the Education Personnel Certification Act in April 2008 to set a ten-year term of validity for teaching licenses. This amendment requires the teachers working in the primary and secondary education sectors to renew their teaching licenses every ten years by taking thirty hours or more of in-service training. The training aims to update teachers' knowledge and skills in education and is divided into two areas of training: twelve or more hours of a required program and eighteen or more hours of elective programs. The required twelve-hour training aims to foster teachers' understanding of the current state of education, particularly the changing characteristics of children, the teaching profession, building partnerships between school and community, and the directions of educational reforms, while eighteen hours or more are devoted to programs on matters relating to pedagogy and guidance. For this latter part of the training program, teachers can choose several courses aiming to develop their instructional skills, expertise on subject matter, and skills for guidance. Our teacher education course was certified as a program for this elective part.

### **The direction of change and its impact on teacher training**

A process of planned change by MEXT has been underway for some time in Japan, with

emphasis being placed on ideas that relate to communicative approaches to teaching in contrast to more traditional teacher-centred classrooms. An example of this is the Ministry's Action Plan to Cultivate English with Japanese Abilities (APCJEA), which was implemented from 2003 to 2007. Part of the plan was to move towards classroom teaching that was less teacher-centred and involved students in more interactional classroom activities. In order to achieve this objective, the plan also specified the provision of teacher training so that teachers could "cultivate students' practical communication abilities". Training was organized by the prefectural boards of education and supported at the national level. In Hiroshima Prefecture, this involved teachers attending about ten one-day training sessions within the period of the APCJEA. In addition to the APCJEA, the centrally produced syllabus documents (the *Courses of Study* for junior and senior high schools) were also revised to promote more communicative classes.

More recently, the Ministry announced a new revision of the *Course of Study* for junior high schools in March 2008, and this was followed by the announcement of a revision of the senior high schools' *Course of Study* in March 2009. One of the key points of the revisions is "integration of the four skills." In the new version, the aims of the English courses for junior high school students stress a balanced development of all the four skills. For high schools, the labelling of the English courses has been changed: The current "English I, II, III" are to become "Communication English I, II, III." This change of labelling is a reflection that these courses are not skill-specific, but integrative, aiming to develop students' ability in all the four skills. This illustrates the move towards much more integrated courses, oriented towards developing students' abilities in all four skills, which will be reflected in the textbooks approved by the Ministry.

## THE SET-UP OF THE COURSE

One day was allocated to the teacher training course which we developed. It involved a short introductory session, three main sections of instruction, and a period of evaluation. The course was taught both in Japanese and English, and at any one time, the language used was chosen on the basis of its appropriacy. It was organized as a workshop, and participants were grouped in fours, so that they could perform both groupwork and pairwork.

In the introductory session, a small amount of time had been allocated to introductions. This was extended as all participants arrived early, and provided the opportunity for instructors to circulate around tables and talk with the participants about their schools and situations. The remaining time was spent introducing the timetable for the day, introducing the campus, and fulfilling administrative requirements.

The course itself was divided into three main sections: The utilization of textbooks; grammar instruction; working with AETs. Each of these sections was connected to a theoretical model (Nation, 2008), which was illustrated through the use of secondary school classroom activities throughout the sections. Periods of time were also allocated to allow participants to reflect on their own classroom contexts.

The first section focused on how to use secondary school textbooks in a much more communicative way. The Nation model was introduced as a tool for creating a balance of activities in the classroom, based on his four strands of Input, Output, Language Focus, and Fluency. Each strand was illustrated with activities which could be used in secondary school classrooms, and these activities used materials that were drawn from Ministry-approved school textbooks that are currently in use, covering both junior and senior high school levels. Participants experimented with these materials.

The second section built on the overview by focusing on grammar instruction, which falls within the Language Focus strand of the Nation model. Materials were drawn from both junior and senior high school textbooks. Ways of presenting grammar were illustrated and participants were asked to think through how to teach a grammar point using materials drawn from two textbooks. They were encouraged to use focused questions, and both inductive and deductive tasks, in order to highlight grammatical features and encourage students to map meaning to form.

In the third section of the course, participants were asked to focus on team teaching with Assistant English Teachers (AETs) by reflecting on their own team-teaching experiences and considering examples of AETs' reflections on what makes team teaching fulfilling or unfulfilling. This was followed by a subsection that focused on classroom activities that specifically focused on the life experiences of teachers and students in contrast to text-based materials. At the end of the section, time was allocated to a discussion of key factors in good working relationships in team-teaching situations.

Evaluation of participants was required for all courses of the program. In the evaluation stage of the course, participants were asked to draw together the ideas from the sections by writing plans for a team-taught lesson based on textbook materials.

## THEORETICAL IDEAS

Central to planning the teacher-training course was the desire to connect theory with practice in a way that was accessible to the course participants. Literature on effective educational change emphasises classroom practice as a central focus and it was important that the content of the course acted as a bridge between the direction of change and teachers' classroom situations. In order to create a cohesive course, an appropriate theoretical model was illustrated using a wide range of practical classroom activities for secondary schools. This combination of theory and classroom activity reflected ideas emerging from a review of publications on English language teaching in Japan, which come from both secondary school teachers themselves and university professors. The review indicated a tendency for publications by secondary school teachers to focus more heavily on classroom techniques while university professors typically emphasize theoretical models.

The use of a model combined with activities was in keeping with Widdowson's (1991) argument for a pragmatics of pedagogy: "I mean the working out of a reflexive, interdependent

relationship between theory and practice, between abstract ideas deriving from various areas of enquiry and their actualization in the achievement of practical outcomes” (p. 30). He argues that it is teachers who have to assess the relevance of ideas to their particular classroom contexts. From this perspective, the training course would be most effective if set up on a workshop basis, with the introduction of a theoretical model acting as an organizing principle, illustrated through pair and group activities designed for students, and with time allocated for participants to consider the activities with reference to their own teaching situations. This format would allow teachers to make an assessment of their practicability and evaluate them in the light of the model, which had to be as relevant to the teaching situations of the participants as possible.

It was also important to find a working model for teachers, which could be used easily in planning and teaching classes, and which connected to their own teaching situations. In relation to approaches and methods, Richards and Rodgers (2004) note that they are often seen as all-purpose solutions to teaching problems, but that the contexts of teaching and learning situations are often ignored. Nunan (1989) argues that under the umbrella term of the communicative approach there are in fact a family of approaches. The result of this is that the literature on theory is extensive, and a key aim was to select a “family member” that fitted with the context of Japanese secondary education and the variety of participants attending the course.

In terms of the Japanese context, the educational stage at which English language classes become mandatory is junior high school. Although some children start learning English at earlier ages, many state school teachers have to teach the complete basics of English to their students; the state school system also allows selection of students at secondary level, and in Hiroshima Prefecture there are no longer school districts, so that students are not restricted geographically in their choice of school. In practice, this means that state schools vary considerably, ranging from very academic elite schools at one end of the spectrum to schools in rural areas that provide a basic education to their local communities. All schools are expected to follow MEXT’s *Courses of Study* and must use textbooks which have been approved by the Ministry of Education. These textbooks are published by private companies who seek Ministry approval, so that a range of textbooks is on offer at any one time. Most Japanese teachers of English (JTEs) are involved in team teaching, where they work with an Assistant English Teacher (AET) from an English-speaking country. However, as there are only a small number of AETs in relation to JTEs, AETs are usually shared between a variety of classes during a semester, so that where a JTE will be present for a whole course, the AET may only attend two or three classes. In addition to teaching classes, JTEs are involved in a variety of responsibilities, ranging from involvement in club activities for students to pastoral care, so that they are often under a lot of time pressure, much of it unrelated to classroom teaching.

Given the direction of change and the teaching context, the move away from teacher-centred classes involving more student interaction requires a focus on pair and group activities. However, teachers have to work with textbooks which, in their text-based organization, do not necessarily orient towards this.

Consequently, one aspect of the course was to aim to show how materials from such government-approved textbooks could be used interactively by students, and through the use of a theoretical model, how teachers could create a balance of activities in the classroom.

The central section of the course was allocated to a focus on form. With the Ministry promoting more student-centred, meaning-oriented classrooms, a key issue was integrating a focus on form into a set of activities that are primarily communicative and meaning-focused. Regarding the issue of whether grammar can be learnt through communication and tasks alone, there is little empirical evidence to support this idea, and this is especially the case in EFL contexts where input levels are low. Communication tasks can reinforce grammar learning but as learners' attention should be on meaning, and not form, during communication, the risk is that learners fail to 'notice' (Schmidt, 1995) new forms to the degree required for acquisition to take place. Consequently, this part of the course was designed to highlight form-focused instruction that takes place in meaningful contexts, with the aim of maintaining positive, motivated attitudes among learners.

A final aspect of the course related to human resources, where participants were asked to consider how to utilize AETs in a constructive way. The text-based activities from the first section of the course were complemented in the last stage with activities that utilized students' own life experiences. These are also the kind of activities that AETs are encouraged to use, so the final section of the course was used to consider how JTEs could share work in lesson preparation and teach effectively with AETs.

### Finding an appropriate model

In relation to the new *Courses of Study*, one of the key changes is the emphasis on the integration of the four skills in teaching classes and the development of students' abilities in those skills. It was therefore important to find a model that emphasised a balance. Some experts such as Harmer (2007) claim that an integrative approach should be taken because it is an effective way of teaching. The idea of integration can be seen to apply both to the integration of the four skills and to the integration of key aspects of second language acquisition processes.

In her overview of second language acquisition, Ortega (2009) lists five key factors involved in SLA processes: input, interaction, output, attitudes and attention. If theory on SLA is to be applied effectively to classroom instruction, pedagogical models which incorporate this theory are needed. Harmer (2007) argues that an integrated approach maximizes learning opportunities. Another important writer in this area is Nation (2008), who claims that a language program should balance four main strands: Meaning-focused input, Language-focused learning, Fluency, and Meaning-focused output. These concepts provide a pedagogical parallel to Ortega's key components, and therefore provide a solid bridge between SLA theory and classroom instruction. The ways in which Nation recommends the activation of his strands are summarized below:

Meaning-focused input:

Listening and reading. Learners' attention is on comprehending the message.

Language-focused learning:

Deliberate attention to linguistic features. Includes activities such as direct teaching of vocabulary and grammatical exercises.

Fluency:

Repetitive practice of known material in all the four skills to speed up processing.

Meaning-focused output:

Speaking and writing. Learners' attention is on conveying their message.

Nation (2008) suggests that a language course should balance the four strands by allocating roughly the same amount of time for each one. Moreover, Nation (2008) endorses the balancing of the four strands in any language program, whether it is an overall, integrated program, a program targeting a specific skill, or a vocabulary program. This distinguishes his standpoint from the one behind the revision of the *Course of Study*, which endorses integrative teaching because it aims to achieve a balanced development of ability in all the four skills of reading, listening, speaking and writing.

Why is integration effective? Harmer's (2007) comment that it maximizes learning opportunities sounds reasonable intuitively, but he does not explain theoretically why this is the case. Nation (2008) explains the benefits of each strand in his model, but this still leaves open the question of why it is that four strands must be balanced; Why not three or five, and how are they connected with each other?

### **Cognitive accounts of the effectiveness of integration**

In terms of an explanation of the effectiveness of integration, Muranoi (2006) proposes a model which combines a description of the overall cognitive process of second language acquisition and a classification of teaching activities to show what type of teaching facilitates what part of the acquisition process.

Muranoi (2006), largely drawing on Gass (1997), phases the overall process of acquisition into four stages: Noticing, Comprehension, Intake, and Integration. Noticing, or Apperception in the Gass (1997) model, is a process in which a learner detects a piece of language by directing his/her attention selectively to relevant stimuli. This detection takes place when a learner tries to relate incoming stimuli to existing knowledge, or finds a hole in his/her knowledge. The information detected in this stage is then analysed further. The next stage, Comprehension, involves different levels of comprehension, spanning from semantic understanding to detailed structural understanding. Gass (1997) points out that the degree of analysis in this stage will affect the likelihood of input being turned into intake. Intake involves hypothesis testing, and at this stage the learner turns input to grammar by matching information to his/her existing grammar. This processing is followed by Integration, in which a learner modifies his/her grammar based on the information gained in the previous stages.

Muranoi (2006) also proposes a classification of teaching activities. This is a modification of the traditional PPP model (Presentation-Practice-Production) that developed from situational language teaching (Richards and Rodgers, 2001). Muranoi (2006) modifies this scheme to accommodate content-based teaching with textbooks by adding the Comprehension component. Presentation is a lead-in to Comprehension (e.g., oral introduction, semantic mapping); Comprehension is the stage in which learners read/listen for meaning; Practice refers to activities to develop skilled control of linguistic codes (e.g., shadowing, read-and-look-up, sight translation); Production is the category for output activities (e.g., story retelling, summarizing).

Muranoi (2006) maps this classification of teaching activities onto the overall process of SLA to show phases of acquisition engaged by each type of teaching activity, as summarized in Figure 1.

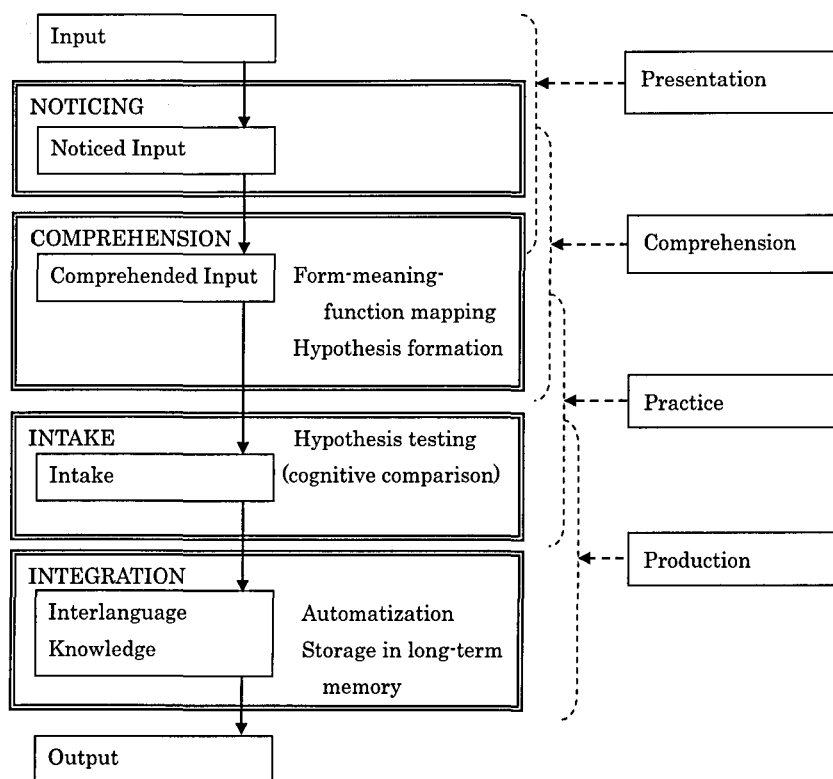

Figure 1. Summary of Muranoi's (2006) model

Figure 1 shows that one type of activity alone does not activate all the cognitive processes involved in acquisition; activities relating to a particular stage form only a part of the overall acquisition process. In order to engage all the processes of acquisition, it is necessary for teachers to combine different types of activities so that they complement each other.

### **A working model**

Integration is the act of putting separate pieces together. What are the pieces that language teachers need to integrate? The four skills and grammar are often raised as components of integration, but they are not all that teachers do in class. While Muranoi's (2006) PCPP provides a good theoretical model for why integration is valuable, it also suffers from a variety of weaknesses. For example, the Practice category includes a very wide range of activities, and this can cause difficulty when applying this model to class planning. In his classification, various types of exercise involving translation (e.g., sight translation) and repetitive exercises such as reading aloud are placed under the same category of Practice. However, translation exercises and reading aloud are used for different purposes, the former for the analysis of input, and the latter for consolidation of newly learnt items. It also fits much more closely with the layout of materials for senior high school textbooks, which often involve a reading or listening passage early in each chapter.

In contrast, Nation's (2008) four-strand scheme is readily applicable to a wide range of teaching contexts. When this four-strand scheme is mapped onto the SLA process shown in Figure 1, it is evident that the four strands cover all the processes of acquisition and the types of teaching activities: Meaning-focused input overlaps with Presentation and Comprehension; Language Focus is equivalent to activities categorized under Practice, although this category includes a wider range of activities than Language Focus; those activities that are not within the scope of Language Focus will fall under the category of Fluency activities. Fluency activities involve repetition of already familiar items so that they can be processed faster; this also partly overlaps with Production, responsible for automatization. Meaning-focused output, as the name suggests, includes speaking and writing activities, which are categorized as Production in Muranoi's (2006) classification. Consequently, while Muranoi's model offers a good theoretical basis for why integration is valuable, Nation's model, in its flexibility, offers a better analytical tool for classroom practitioners dealing with the complex and unpredictable challenges of classroom realities.

## **THE THREE SECTIONS OF THE TEACHER TRAINING COURSE**

### **Using the four strands in a textbook-based class**

One of the advantages of the Nation model is its flexibility. In contrast to some models, it can accommodate both old and new ideas on teaching. For example, Nation and Newton (2008) point out that it is important for teachers to recognize that "traditional" or "old-fashioned" ways of teaching, such as translation and pattern practice, do have a role in effective teaching, if used



appropriately. In their model they stress balance between the four strands, so that it is the excessive use of a particular activity that should be avoided, not whether it is considered traditional or new. For example, translation can be a good way to direct learners' attention to form, and this can be part of a repertoire of activities for Language Focus; pattern practice can be a good option for Fluency because learners repeat phrases so that they can utter them smoothly and comfortably. If these ways are used carefully in the strand to which they fit most closely, and are contextualized alongside activities designed to cover the remaining strands, then they can be used effectively. Examples of activity types are listed under the four strands in Table 1.

Table 1. Examples of activities

#### *Meaning-focused Input*

- Reordering sentences: Learners talk to other learners to collect and reorder sentences.
- Asking questions to fill in gaps: Learners work in pairs, and each of them receives a passage with some gaps; they ask their partner questions in order to fill in the gaps.

#### *Language Focus*

- Corrupt translation: Learners are given a translated text which contains some deliberate mistakes; they read it to find the mistakes.
- Dictation plus reproduction: The teacher dictates a passage, and the learners write down the initial letters of the words. Later, they work in pairs: one learner reads the passage aloud by reconstructing it from the letters they have written down, and the other learner, while looking at a complete passage, corrects his/her partner's mistakes.

#### *Fluency*

- Pair work in reading aloud: To maintain learners' focus on the activity, reading aloud is done in pairs; when reading a passage, learners take turns sentence by sentence, or word by word.
- Interpreter training: A passage is translated phrase by phrase, and the translation and the original text are printed in parallel; learners form pairs; one of them says a translated phrase, and the other learner says the corresponding English phrase.

#### *Meaning-focused Output*

- Jigsaw: Learners work in a group, and each learner receives a different piece of a longer text; they explain the content of the given piece to the other members of the group.
- Guess and Confirm: Learners form a pair, and one of them receives a complete text, and the other receives a gapped text; the one with a gapped text guesses the content of the story and tells the other person about his/her guesses; the person with a complete text corrects the mistakes in his/her partner's guesses.

When planning teaching, it is necessary for teachers to recognize that the four strands are integrated so that activities are devised that complement each other, balancing the strands across a chain of activities that students undertake in the classroom. No single activity alone can engage all the processes of acquisition, as shown in Figure 1. Thus, in planning a class, teachers need to recognize which of the four strands a particular activity capitalizes on and which strands it does not.

Comprehension questions are used as a way to engage learners in comprehending a text, so this activity capitalizes on Meaning-focused Input, while it does not direct learners' attention to linguistic form, urge them to repeatedly read the text so that they can read faster, nor require them to produce output. In this sense, the function of comprehension questions can be represented as follows (the four strands are abbreviated as I (Meaning-focused Input), O (Meaning-focused Output), L (Language Focus), and F (Fluency)):

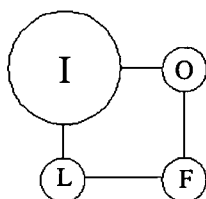

Dictation is an activity to direct learners' attention to form, and thus capitalizes on Language Focus, while there is no emphasis on the other three strands. The degree to which this activity fosters each strand can be illustrated as follows:

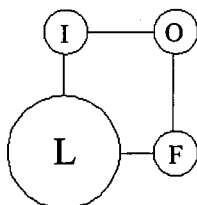

Reading aloud is often employed as a way to consolidate students' knowledge of the language. This activity can be interpreted as capitalizing on Fluency because students read aloud repeatedly so that they internalize the language itself and vocalize the language comfortably. The following diagram summarizes the function of this activity:

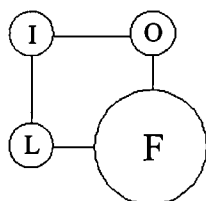

Story retelling is an activity in which students speak about the content of the passage that they have already learned. This is used as a speaking activity, and thus serves as Meaning-focused Output. The function of this activity can be represented as follows:

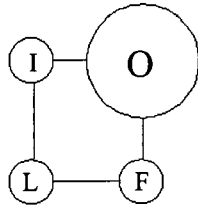

When different types of activities are combined, instruction can be balanced. If the four example activities above are employed, they complement each other so that their constellation gives due emphasis to all four strands.

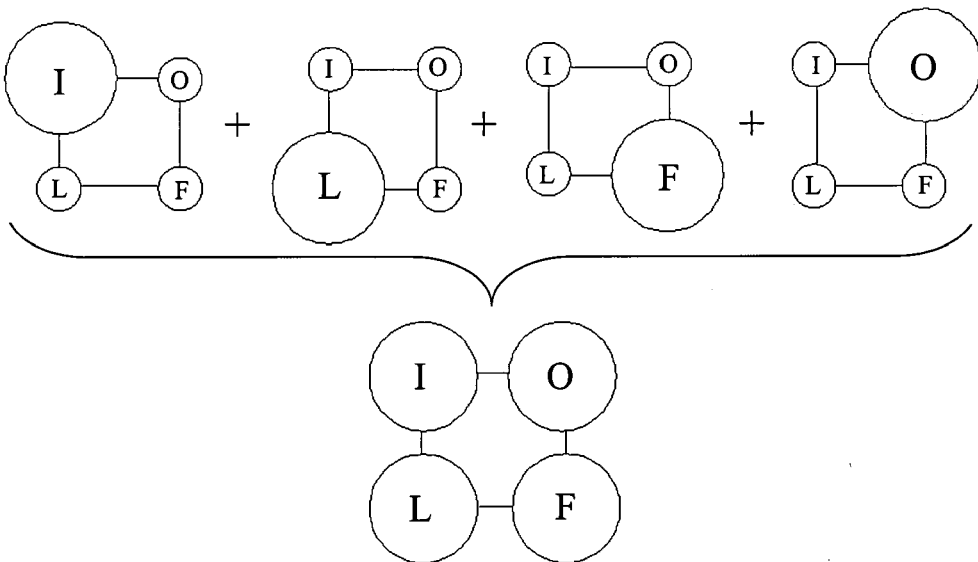

In some cases, an activity addresses more than one strand. For example, Jigsaw involves both Meaning-focused Input and Output in so far as learners read a passage, comprehend the message in it, and report it to other students. Other activities such as Guess and Confirm also involve more than one strand. The function of these activities can be represented as follows:

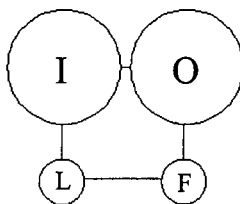

However, an interpretation of which strand an activity covers is not always straightforward. It could vary depending on the context of teaching. This is an important issue in putting Nation's model to use and is considered in more detail in the discussion section.

Note that many of the examples in Table 1 incorporate pair work and group work. This is to make the activities meaningful and motivating. Input and output activities will be more meaningful if there is a conversation partner than if students work alone. Traditional activities such as dictation and reading aloud, often regarded as mechanical and boring, can be made more interesting and exciting if students work with others. A key point in making pair work and group work successful is to create a situation where students cannot complete the task without help from other students. Learners in such a situation will have a sense of responsibility and cooperate with other students (Jacobs, 2006).

### **Language Focus: Integrating grammar**

A focus on form is one of the four components (Language Focus) of Nation's (2008) model, incorporating such aspects as pronunciation, intonation, and grammar. As it represents one of the most 'controversial' aspects of language instruction, with so much debate about how best it should be taught, it was given a specific focus in the course. With the growing trend towards more communicative instructional approaches, grammar instruction represents perhaps the most difficult aspect for teachers who are trying to teach English in a manner which is communicative and connects the classroom to using English in the wider world. In the Japanese EFL context, grammar instruction has often been teacher-led and taught in a didactic and non-communicative manner. The key issue in this part of the course was how to get students more involved in learning language forms. It should also be noted here, that Nation's model as described above shows how the Language Focus strand should not be taught in isolation from the other strands, but benefits from being integrated with language Input and Output, while Fluency activities provide the opportunity for new language to be practised and automatized.

In the most comprehensive overview of studies on instructed language acquisition to date, Norris and Ortega's (2000) metaanalysis shows that whilst both explicit and implicit instruction of morphosyntax are effective, the effect sizes for explicit instruction are significantly greater. In EFL environments, where incidental learning processes caused by extensive input are much less likely to be activated, the need for activities which bring learners' attention to new linguistic forms is even greater. However, there is a danger that these findings may be misinterpreted as justifying a return to decontextualized teacher-fronted grammar instruction. This is absolutely not the case, and this was one of the key points of this section of the teacher-training program. When learning new language forms it is vital to map the new forms onto meaning and use. When grammar is taught as a set of rules isolated from meaning and use, it is very difficult for learners to understand how the new forms connect with their current interlanguage. For successful acquisition of new forms to take place it is important to engage learners' attention to those forms in meaningful contexts. In order to achieve this: (1) students need to be more personally involved in learning grammar; and (2) the teacher needs to find ways to help learners

make strong form-meaning mappings. In other words, teachers need to find ways to make a focus on language both challenging and enjoyable for students; by connecting the language focus with language input, and encouraging learners to use new language forms in their output, the function of new forms is likely to become much more salient to learners. Consequently, the main point of the section was to explore passages from textbooks, identifying key grammatical structures within them and planning how to guide their students in an active process of understanding their function, mapping meaning onto form.

### Working with AETs

This section focused on how AETs could be effectively brought into the planning and teaching of classes, particularly with reference to the Nation model. The amount of contact between JTEs and AETs can vary considerably, depending on the policy of a particular school in allocating AETs to classes. It is possible for an AET to be involved in every class of a course, but the more common case involves an AET being shared amongst classes so that he/she participates in only a few classes of an overall course.

Writers such as Tajino and Tajino (2000) have pointed out that in team-teaching situations, there is a risk for both JTEs and AETs: The lesson may be dominated by the JTE, so that the AET may become relegated to the role of human tape-recorder; conversely, if the JTE cedes the class completely to the AET, the JTE's role may become that of being an interpreter. This risk is reduced through the use of pair and group activities, as illustrated in Figures 3 and 4 below.

The first two sections of the course focused on ways of utilising passages of English in much more communicative ways in the classrooms. However, there is also another resource open to language teachers: life experiences of the students themselves. Parts of classes can be oriented towards life experiences in terms of content, and used to help students link such experiences to more text-based content. Also, in contrast to a written text, where a student has to work to understand the text, Output activities involve life experiences that are inherent to the student, but the student has the pressure of trying to articulate them in a foreign language. In sharing experiences, students may also find opportunities for further interaction.

Given that contact with AETs can vary, the first part of the section involved asking the participants to reflect on and discuss their own experiences in team teaching, and to highlight ways in which AETs can find the team-teaching experience fulfilling or unsatisfying by drawing on research in this area, and to consider what factors made team teaching effective. This was combined with activities which could strongly involve an AET.

Mingling activities, involving questionnaires where students are required to ask questions to their teachers and classmates, allow both the JTE and AET to engage with students at the same time, with both teachers fully involved in the activity as participants. This also connects with aspects of the APCJEA:

“Also, a native speaker of English provides a valuable opportunity for students to learn living English and familiarize themselves with foreign languages and cultures. To have

one's English understood by a native speaker, increases the students' joy and motivation for English learning." (Part I, section 2)

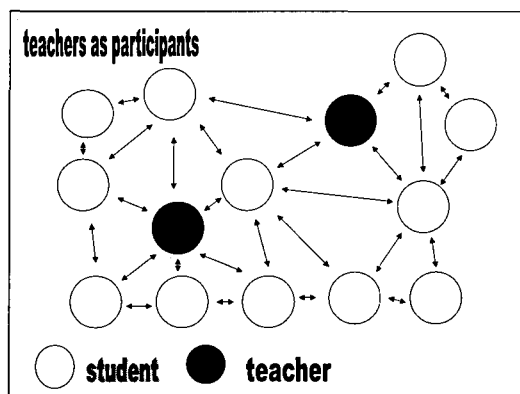

Figure 2. Interaction in a mingling activity

Pair questionnaires allow teachers to model questions and give example answers, before students work in pairs. In the case of an AET providing model answers, this can be used as an Input activity for students. When students then use the questionnaire to ask and answer questions, this becomes primarily an Output activity, and both teachers can use their time to monitor and aid students:

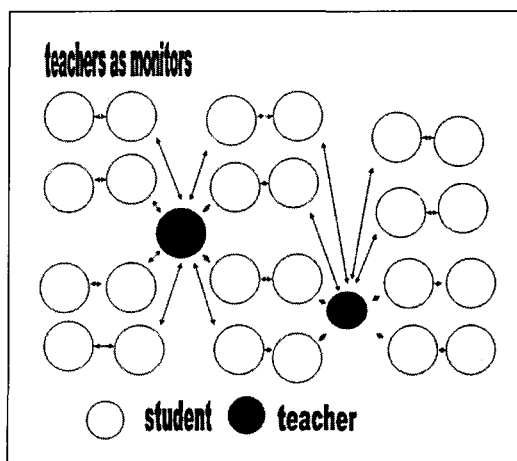

Figure 3. Interaction in a pair activity

The advantage of questionnaires is that they can be used flexibly within several strands of the Nation model. Although intuitively they align closely with Output, where students are responding to pre-prepared questions, they can also be used for Input, or designed to encourage a subconscious pattern practice, where students repeat particular structures in the form of questions, thus aligning with Fluency.

## DISCUSSION

The teacher training course was developed and taught with reference to a specific risk: In applied linguistics, theory is written to inform practice, but there is often a separation between ideas espoused by theorists and those of classroom practitioners. For a busy classroom teacher, it is very important to see how classroom practice can be changed with reference to theory. A major aim of the course was to act as a bridge between theory and practice. Central to this was our decision to draw on the existing resources available to teachers in the form of Ministry-approved textbooks: In the first two sessions of the training course, all the materials used were drawn from these materials, and theoretical ideas were illustrated through classroom activities using these materials.

In terms of connecting theory and practice, another key issue was to find a “working model” for teachers. Most theoretical models are complex, and are used to illustrate particular aspects of the learning or teaching process. The model for the course had a particular purpose: It needed to act as a planning tool for classroom teachers, so that in the process of planning and teaching classes, they could use it as a simple way of analysing both activities themselves and the balance of activities in their classes. While ideas such as Murano’s give insight into cognitive processes, the Nation model formed the backbone of the course because of its simplicity and flexibility; teachers have to deal with classroom realities, involving multiple factors that are often complex and unpredictable. Analysing classroom activities into four strands is a straightforward way of keeping a good balance.

Further issues relate to teacher decision-making in relation to particular classroom contexts. Ultimately, it is secondary school teachers who have to make decisions about what to teach and how to teach in their classrooms. While new ideas may come from training courses, it is the secondary school teachers who have to evaluate them and make decisions on how or whether to change their classroom practice. This was one reason why the course was set up on a workshop basis. Within the time constraints of a one-day course, periods of time were given over to discussion where teachers could reflect on their own situations and think through how they might use some of the ideas on the course. This also allowed the teacher-trainers to sit with small groups of participants and to get an understanding of the situations of those teachers. In terms of developing teacher-training, an ongoing dialogue between instructors and participants is an important component of the process.

Two important aspects of the teacher decision-making process in the Nation model are the balance of activities in relation to the stages of student development, and the interpretation of activities. In relation to the former, the teacher-training course included participants from both junior and senior high schools and it is important to consider whether Nation’s emphasis on allocating roughly equal time to the four strands holds for both of these levels. It is also important to consider how teachers may interpret activities in light of their own students.

Nation’s ideas are more open to criticism in the assumption that there should be an equal balance between Input, Output, Language Focus and Fluency. Teachers plan instructional goals

in consideration of students' proficiency level. Depending on the students' developmental stage, teachers set priorities on areas of instruction. This contradicts Nation's assumption that roughly equal time should be spent on all the four strands. For example, beginners have only a limited knowledge in the target language, and priorities of instruction are likely to be on developing basic vocabulary and grammar. This inclines teachers of learners at this stage to place more emphasis on deliberate learning and practice of new linguistic items, which are Language Focus and Fluency in Nation's scheme, while limiting the amount of Input and Output activities. On the other hand, in teaching learners at an advanced stage, teachers will probably devote more time to activities urging learners to use the target language, which are Meaning-focused Input and Output in Nation's scheme, but less time will be spent on Language Focus and Fluency, because learners at this stage may have already attained high fluency in manipulating linguistic codes. Nation's idea of allocating equal time to each of the four strands could sometimes lead to unrealistic instructional plans. This suggests that there should be some flexibility of emphasis on each strand depending on students' proficiency level. Teachers need to be careful, however, not to omit any one of the four: Placing less emphasis does not mean the strand can be neglected.

Another key issue was the openness of many activities to different interpretations. The outcome of an activity is highly dependent on the levels and abilities of students. It is possible that an activity can be interpreted differently. If an activity involves several skills, such as Jigsaw, in which learners read a passage and report its content to other learners, the function of the activity could be differently interpreted depending on which aspect of the activity a teacher prioritizes. Some teachers may interpret this as an Input and Output activity since it involves both reading and speaking. However, the same activity may be interpreted as an Input activity: reporting may be used merely as a driver for careful reading. Or, it may be an Output activity: the reading phase is just a preparation for speaking. These interpretations are all highly dependent on context. Interpretations could vary because teachers place an emphasis on different aspects of an activity in consideration of various factors such as course objectives, time constraints, and students' proficiency level. In this sense, the Nation model is useful in its simplicity: Based on their experiences with their own students, teachers can use it to analyse activities in planning and make adjustments in the light of the actual results in the classroom. Furthermore, the simplicity also allows for flexibility. Classroom realities are usually much more complex and unpredictable than the idealizations of most models, with teachers having to adapt and innovate according to circumstances. The Nation model allows teachers to make rough practical judgements on particular activities, so that they can maintain a balance of activities depending on their judgement of what a particular set of students need at a particular time.

In relation to terminology, one further issue that emerged in the planning and teaching of the course was the definition of the term "fluency." There appear to be two major concepts which are subsumed under the one term. Nation's use of fluency might be described as fluency of processing, with a heavy emphasis on automatization. This is in contrast to fluency of communication, where the focus is on an ability to both take in and express ideas clearly. While



the two concepts are linked, they are not the same. With the Nation model, fluency of communication might be considered an overall goal, which is achieved through balancing the four strands. In the course, the Nation model was explained in Japanese in order to make sure that there was no confusion in how the word “fluency” was used. However, expanding this use of the term to “fluency of processing” would help to avoid confusion.

## CONCLUSION

In summary, the teacher-training course was set up as a bridge between theory and practice, with planning starting from a consideration of the circumstances of teachers working in secondary education, and with a particular focus on how they could use the resources around them to best effect. The Nation model was chosen on account of its ease of use as an analytical tool by teachers in their working lives. Areas of the course were focused on using textbook materials in more communicative ways, contextualising grammar in more communicative classrooms, and working with AETs.

The course might best be described as a workshop, with instructors interspersing periods of presentation with participant activities. These fell into two categories: engaging in activities that could be used with students in their classrooms and discussion activities on teachers’ particular teaching contexts. Participant evaluation was also oriented towards classroom use with participants being asked to write lesson plans based on textbook passages.

Finally, it is important to note that this article has focused mainly on the ideas that lay behind the creation of a teacher-training course, which was created as part of a specific program of in-service training. Although the course was developed for a specific context, many of the ideas themselves have a much broader relevance, extending beyond secondary education into tertiary education, and so these have formed the main part of the article. The emphasis of the course was placed on developing an understanding of a model that can act as a tool for assessing what particular activities are likely to achieve in the classroom. While teacher-training courses can offer ideas and ways of evaluating the complexities of actual classrooms, ultimately, it is a particular teacher in a particular context who has to plan and teach a language course; it was in this spirit that the course was developed.

## References

- Harmer, J. (2007). *The practice of English language teaching* (4th. ed.). Harlow: Pearson Longman.
- Gass, S. M. (1997). *Input, interaction, and the second language learner*. Mahwah, NJ: Lawrence Erlbaum Associates.
- Jacobs, G. M. (2006). Issues in implementing cooperative learning. In S. G. McCafferty, G. M. Jacobs, & A. C. DaSilva Iddings (Eds.), *Cooperative learning and second language teaching* (pp. 30-46). Cambridge: Cambridge University Press.
- Ministry of Education, Culture, Sports, Science and Technology. (2003). *Action plan to cultivate*

- "Japanese with English abilities" [www.mext.go.jp/english/topics/03072801.htm](http://www.mext.go.jp/english/topics/03072801.htm)
- Muranoi, H. (2006). *SLA research and second language learning and teaching*. (Daini gengo shuutoku kara mita koukatekina eigo gakushuu hou sidou hou) Tokyo: Taishuukan Shoten.
- Nation, I. S. P. (2008). *Teaching ESL/EFL reading and writing*. New York: Routledge.
- Nation, I. S. P. & Newton, J. (2008). *Teaching ESL/EFL listening and speaking*. New York: Routledge.
- Norris, J.M. & Ortega, L. (2000). Effectiveness of L2 instruction: A research synthesis and quantitative meta-analysis. *Language Learning*, 50, 417-528.
- Nunan, D. (1989). *Designing tasks for the communicative classroom*. Cambridge: Cambridge University Press.
- Ortega, L. (2009). *Understanding second language acquisition*. London: Hodder Education.
- Richards, J. C. & Rodgers, T. S. (2004). *Approaches and methods in language teaching* (2nd. ed.). Cambridge: Cambridge University Press.
- Schmidt, R. (1995). Consciousness and foreign language learning: A tutorial on the role of attention and awareness in learning. In R. Schmidt (Ed.) *Attention and awareness in foreign language learning* (pp.1-63). Honolulu: University of Hawai'i, Second Language Teaching & Curriculum Center.
- Tajino, A. & Tajino, Y. (2000). Native and non-native: What can they offer? Lessons from team-teaching in Japan. *ELT Journal*, 54, 3-11.
- Widdowson, H. G. (1991). *Aspects of language teaching*. Oxford: Oxford University Press.

## 要 約

### 実践に活きる研修：中学・高校英語科教員に対する教員免許更新講習の設計

磯 田 貴 道

ウォルター・デイビス

ケネス・フォードイス

広島大学外国語教育研究センター

本稿は、2009年に実施した教員免許更新講習の概要を報告し、講習の計画を通じて浮かび上がった、授業実践に資する教員研修や理論のあり方について考察するものである。講習のテーマは、四技能をまたいだ言語活動で英語力を高める授業であった。これは学習指導要領の改訂により、中学校、高等学校とも四技能すべてを含めた統合的な授業が求められている点を重視したことによる。

講習は3つのセクションからなる。それに先立ち、講習の柱となる Nation (2008) の理論が紹介された。この理論は、効果的な授業を行うためにはバランスをとることが重要で、そのためには Meaning-focused Input, Meaning-focused Output, Language Focus, Fluency の4つの領域を含める必要があると説くものである。それに続いて第一のセクションでは、教科書の活用方法が取り上げられた。手持ちの教科書の文章を活用して、上記の4つの領域をカバーする活動を作る方法が紹介された。第二のセクションでは、文法指導とコミュニケーション活動の融合をテーマに、コミュニケーション活動の文脈の中で文法を指導する方法が紹介された。これは Language Focus を Meaning-focused Input と Meaning-focused Output と関連付けるものである。第三のセクションでは、ALT の活用がテーマであった。第一のセクションでは教科書をリソースとしているが、この講習では生徒自身の経験をリソースとし、Meaning-focused Input, Meaning-focused Output, Fluency に関係する活動を作る方法と、教材作成や授業実施に対して ALT がもたらす貢献について議論された。

講習を計画する上で、特に次の二点を重要視した。一点目は、理論と実践を結び付ける必要性である。授業は様々な要因が交錯する複雑な場であり、教師は状況に鑑み、何をどう教えるかといった判断をしなければならないが、理論はその判断を支援できるものでなければならない。そのために Nation (2008) の理論を柱として講習を計画した。この理論は、4つの領域を含めることでバランスを取るという点が、指導要領により求められる統合的な授業と共通し、かつ第二言語習得研究などの知見とも符合する。また、4つの領域が授業での活動の分類に直結するため、簡便で分かりやすく、かつ幅広い文脈に適用できるという利点もあるため、この理論を教師の判断を支援する指針として採用した。二点目に、講習のあり方も理論が実践に資するものであると身をもって分かる場であればならないという点である。そのために、講習では理論を紹介するだけでなく、参加者が実際に活動に取り組むワークショップ形式で行われた。全ての活動は検定教科書を用いて作成された。また、参加者が自分の授業を振りかえり、講師も交えて他の参加者と対話することで、講習で紹介したことと自分の授業を結び付ける機会も設けられた。