

Long-term Operation Planning of District Heating and Cooling Plants Considering Contract Violation Penalties

Masatoshi Sakawa[†], Shimpei Matsuoka[†], Kosuke Kato[†], Keiichi Ishimaru[‡] and Satoshi Ushiro[‡]

[†]Graduate School of Engineering, Hiroshima University
 1-4-1, Kagamiyama, Higashi-Hiroshima, Hiroshima, 739-8257, Japan
 E-mail: {sakawa, m091737, kosuke-kato}@hiroshima-u.ac.jp

[‡]Urban Facilities Division, Shinryo Corporation
 3-7-1, Nishi-Shinjuku, Shinjuku-ku, Tokyo, 163-1021, Japan
 E-mail: {ishimaru.ke, ushiro.sa}@shinryo.com

Abstract—Urban district heating and cooling (DHC) systems operate large freezers, heat exchangers, and boilers to stably and economically supply hot and cold water, steam etc., based on customers demand. We formulate an operation-planning problem as a nonlinear integer programming problem for an actual DHC plant. To reflect actual decision making appropriately, we incorporate contract-violation penalties into the running cost consisting of fuel and arrangements expenses. Since a yearly operation plan is necessary for check whether the minimum gas consumption contract is fulfilled or not, we need to solve long-term operation-planning problems. To fast and approximately solve long-term operation-planning problems, we propose a decomposition approach using coarse (monthly) approximate operation-planning problems.

I. INTRODUCTION

Urban district heating and cooling (DHC) systems have been actively introduced in Japan to save energy and space, minimize air pollution, and supply hot and cold water, steam etc., to local customers [3] as a shown in Fig.1.

Due to their size and wide range of equipments (Fig.2), DHC plants must be operated reliably, stably, and economically. Such management has come to include heat load prediction [6], [5] and the formulation of DHC plant operation-planning problems of DHC plants as mathematical programming problems [9], [7], [8], [1], [4]. Plant running cost involves electrical and gas utility rates, equipment arrangements cost and even contract-violation penalties – all to be figured into run-cost estimations.

We formulate an operation-planning problem for a DHC plant taking into consideration contract-violation penalties as a nonlinear integer programming problem.

Since a yearly operation plan is necessary for check whether the minimum gas consumption contract is fulfilled or not, we need to solve long-term operation-planning problems. However, it takes enormous time to directly solve them because they are large-scale problems. To fast and approximately solve long-term operation-planning problems, we propose a decomposition approach using coarse (monthly) approximate operation-planning problems.

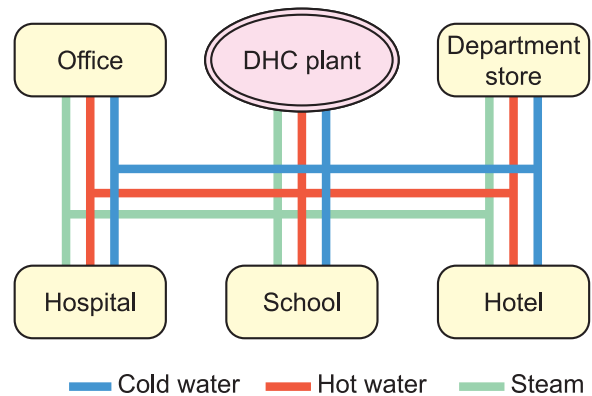

Fig. 1. District heating and cooling system

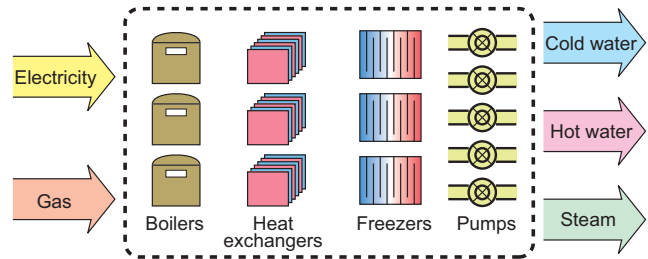

Fig. 2. District heating and cooling plant

II. DHC PLANT OPERATION PLANNING

A. Plant Configuration

A DHC plant generates hot and cold water, steam, etc., by running N_{BW} boilers (p types), N_{DAR} absorbing freezers (q types), N_{ER} turbo freezers (r types), N_{CEX} cold water heat exchangers (s types), N_{IEX} ice thermal storage heat exchangers (u types), N_{HEX} hot water heat exchangers (v types) and ice thermal storage tanks using gas and electricity. Pumps and cooling towers are connected to freezers (Fig.2 and 3).

The optimal DHC plant requires an operation plan minimiz-

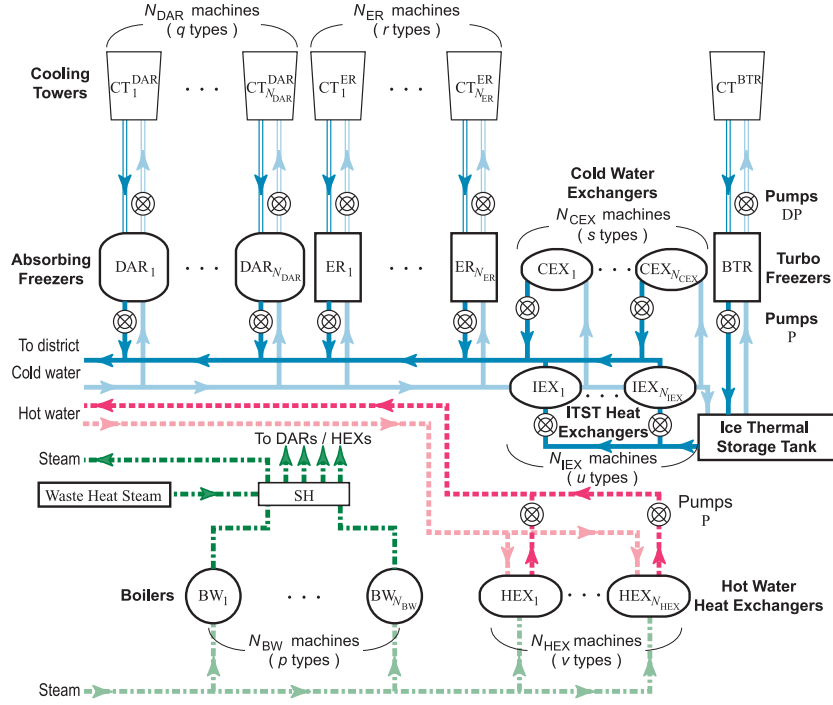

Fig. 3. District heating and cooling plant

ing the cost of gas and electricity providing that plant demand is satisfied by operating equipments.

B. Problem Formulation

Given the (predicted) amount of demand for cold water C_{load}^t , hot water W_{load}^t , and steam S_{load}^t at time t , the operation-planning problem is as follows:

(I) The operation-planning problem involves $(p + q + r + s + u + v + 1)$ integer decision variables. Decision variable (x_1^t, \dots, x_q^t) corresponds to the number of operating absorbing freezers, $(x_{q+1}^t, \dots, x_{q+r}^t)$ to turbo freezers, $(x_{q+r+1}^t, \dots, x_{q+r+s}^t)$ to cold water heat exchanger, $(x_{q+r+s+1}^t, \dots, x_{q+r+s+u}^t)$ to ice thermal storage heat exchangers, $(x_{q+r+s+u+1}^t, \dots, x_{q+r+s+u+v}^t)$ to hot water heat exchangers, while (y_1^t, \dots, y_p^t) to boilers. Decision variable z^t indicates whether a certain condition holds or hot.

(II) The freezers output load rate $P = (C_{load}^t - C_{TS}^t) / C^t$ meaning the ratio of difference between the (predicted) amount of demand for cold water C_{load}^t and the output of the automatically operating thermal storage tank C_{TS}^t to total output of operating freezers $C^t = \sum_{i=1}^{q+r+s+u} a_i x_i^t$ must be less than or equal to 1.0, i.e.,

$$C^t \geq C_{load}^t - C_{TS}^t \quad (1)$$

where a_i is the rating output of the i -th freezer. This constraint means that the total output of operating freezers and heat exchangers must exceed the required amount of cold water generated at the plant, $C_{load}^t - C_{TS}^t$.

(III) Freezers output load rate $P = (C_{load}^t - C_{TS}^t) / C^t$ must be greater than or equal to 0.2 i.e.,

$$0.2 \cdot C^t \leq C_{load}^t - C_{TS}^t \quad (2)$$

This constraint means that the total output of operating freezers must not exceed five times the difference between the (predicted) amount of demand for cold water and the output of the thermal storage tank.

(IV) Hot water heat exchanger output load rate $R = W_{load}^t / W^t$ meaning the ratio of the (predicted) amount of demand for hot water $W_{load}^t = \sum_{i=q+r+s+u+1}^{q+r+s+u+v} w_i x_i^t$ to total output operating heat exchangers must be less than or equal to 1.0,

$$W^t \geq W_{load}^t \quad (3)$$

where w_i is the rating output of the i -th heat exchanger. This constraint means that the total output of operating hot water heat exchangers must exceed the amount of demand for hot water.

(V) Boiler output load rate $Q = (S_{DAR}^t + S_{HEX}^t + S_{load}^t - S_{WHS}^t) / S^t$ meaning the ratio of the required amount of steam generated at the plant to the total output of operating boilers $S^t = \sum_{i=1}^p f_i y_i^t$ must be less than or equal to 1.0 i.e.,

$$-S_{DAR}^t - S_{HEX}^t + S^t \geq S_{load}^t - S_{WHS}^t \quad (4)$$

where f_j is the rating output of the j -th boiler. S_{DAR}^t is the total amount of steam used by absorbing freezers at time t , defined as

$$S_{DAR}^t = \sum_{i=1}^q \Theta(P) \cdot S_i^{\max} \cdot x_i \quad (5)$$

and S_{HEX}^t is the total amount of steam used by heat exchangers at time t , defined as

$$S_{HEX}^t = W^t / 0.95 \quad (6)$$

where S_i^{\max} is the maximum steam amount used by the i -th absorbing freezer. S_{WHS}^t is the amount of waste heat steam supplied from the outside of this DHC system. $\Theta(P)$ is the rate of use of steam by an absorbing freezer, which is a nonlinear function of freezer output load rate P in general. For simplicity, we use the following piecewise linear approximation:

$$\Theta(P) = \begin{cases} 0.8775 \cdot P + 0.0285, & P \leq 0.6 \\ 1.1125 \cdot P - 0.1125, & P > 0.6 \end{cases} \quad (7)$$

(VI) Boiler output load rate $Q = (S_{\text{DAR}}^t + S_{\text{HEX}}^t + S_{\text{load}}^t - S_{\text{WHS}}^t)/S^t$ must be greater than or equal to 0.2 i.e.,

$$-S_{\text{DAR}}^t - S_{\text{HEX}}^t + 0.2 \cdot S^t \leq S_{\text{load}}^t - S_{\text{WHS}}^t. \quad (8)$$

This constraint means that the total output of operating boilers must not exceed five times the required amount of steam.

(VII) Minimizing objective function $J(t)$ is the energy cost that is the sum of gas and electricity bills.

$$J(t) = G_{\text{cost}} \cdot A_{\text{G}}^t + E_{\text{cost}}^t \cdot A_{\text{E}}^t \quad (9)$$

where G_{cost} is the unit cost of gas and E_{cost}^t is that of electricity at time t .

Gas consumption A_{G}^t is defined by the gas amount consumed in the rating operating of a boiler g_j , $j = 1, 2, \dots, p$ and boiler output load rate Q :

$$A_{\text{G}}^t = \left(\sum_{j=1}^p g_j y_j \right) \cdot Q. \quad (10)$$

Electricity consumption A_{E}^t is defined as the sum of the electricity amount consumed by turbo freezers accompanying cooling towers and pumps:

$$\begin{aligned} A_{\text{E}}^t &= E_{\text{ER}}^t + E_{\text{DAR}}^t + E_{\text{HEX}}^t + E_{\text{CT}}^t + E_{\text{DP}}^t + E_{\text{P}}^t \\ &= \sum_{i=q+1}^{q+r} \Xi(P) \cdot E_i^{\max} \cdot x_i^t + \sum_{i=1}^q c_i^{\text{DAR}} x_i^t + \\ &\quad + \sum_{i=q+r+s+u+1}^{q+r+s+u+v} c_i^{\text{HEX}} \cdot x_i^t + \sum_{i=1}^{q+r} c_i^{\text{CT}} x_i^t \\ &\quad + \sum_{i=1}^{q+r} c_i^{\text{DP}} x_i^t + \sum_{i=1}^{q+r+s+u+v} c_i^{\text{P}} x_i^t \end{aligned} \quad (11)$$

where E_i^{\max} is the maximum electricity amount of the i -th hot water heat exchanger, c_i^{DAR} is the electricity amount of the i -th freezer, c_i^{HEX} is that of the i -th hot water heat exchanger, c_i^{CT} is that of the i -th cooling tower, c_i^{DP} is a pump for the i -th freezer and c_i^{P} is that of another type of pump for the i -th equipment. In the above equation, $\Xi(P)$ is the rate of electricity use in a turbo freezer, which is a nonlinear function of freezer output load rate P . For simplicity, we use the following piecewise linear approximation:

$$\Xi(P) = \begin{cases} 0.6 \cdot P + 0.2, & P \leq 0.6 \\ 1.1 \cdot P - 0.1, & P > 0.6. \end{cases} \quad (12)$$

The operation-planning problem is thus formulated as the following nonlinear integer programming problem:

Problem $P(t)$

minimize

$$J(\mathbf{x}^t, \mathbf{y}^t, z^t) = G_{\text{cost}} \cdot A_{\text{G}}^t + E_{\text{cost}}^t \cdot A_{\text{E}}^t \quad (13)$$

subject to

$$-(1 - z^t) \cdot (C^t - (C_{\text{load}}^t - C_{\text{TS}}^t)) \leq 0 \quad (14)$$

$$z^t \cdot (0.2 \cdot C^t) + (1 - z^t) \cdot (0.6 \cdot C^t) \leq C_{\text{load}}^t - C_{\text{TS}}^t \quad (15)$$

$$-z^t \cdot (0.6 \cdot C^t - (C_{\text{load}}^t - C_{\text{TS}}^t)) \leq 0 \quad (16)$$

$$z^t \cdot \Theta_1(P) + (1 - z^t) \cdot \Theta_2(P) + S_{\text{HEX}}^t - S^t \leq -S_{\text{load}}^t + S_{\text{WHS}}^t \quad (17)$$

$$-z^t \cdot \Theta_1(P) - (1 - z^t) \cdot \Theta_2(P) - S_{\text{HEX}}^t + 0.2 \cdot S^t \leq S_{\text{load}}^t - S_{\text{WHS}}^t \quad (18)$$

$$-W^t \leq -W_{\text{load}}^t \quad (19)$$

$$x_i^t \in \{0, 1, \dots, N_{\text{DAR}_i}\}, \quad i = 1, \dots, q \quad (20)$$

$$x_i^t \in \{0, 1, \dots, N_{\text{ER}_i}\}, \quad i = q+1, \dots, q+r \quad (21)$$

$$x_i^t \in \{0, 1, \dots, N_{\text{CEX}_i}\}, \quad i = q+r+1, \dots, q+r+s \quad (22)$$

$$x_i^t \in \{0, 1, \dots, N_{\text{IEX}_i}\}, \quad i = q+r+s+1, \dots, q+r+s+u \quad (23)$$

$$x_i^t \in \{0, 1, \dots, N_{\text{HEX}_i}\}, \quad i = q+r+s+u+1, \dots, q+r+s+u+v \quad (24)$$

$$y_j^t \in \{0, 1, \dots, N_{\text{BW}_j}\}, \quad j = 1, \dots, p \quad (25)$$

$$z^t \in \{0, 1\} \quad (26)$$

where

$$C^t = \sum_{i=1}^{q+r+s+u} a_i x_i^t \quad (27)$$

$$W^t = \sum_{i=q+r+s+u+1}^{q+r+s+u+v} w_i x_i^t \quad (28)$$

$$S^t = \sum_{j=1}^p f_j y_j^t \quad (29)$$

$$P = (C_{\text{load}}^t - C_{\text{TS}}^t) / C^t \quad (30)$$

$$\Theta_1(P) = \sum_{i=1}^q (0.8775 \cdot P + 0.0285) \cdot S_i^{\max} \cdot x_i^t \quad (31)$$

$$\Theta_2(P) = \sum_{i=1}^q (1.1125 \cdot P - 0.1125) \cdot S_i^{\max} \cdot x_i^t \quad (32)$$

$$\Xi_1(P) = \sum_{i=q+1}^{q+r} (0.6 \cdot P + 0.2) \cdot E_i^{\max} \cdot x_i^t \quad (33)$$

$$\Xi_2(P) = \sum_{i=q+1}^{q+r} (1.1 \cdot P - 0.1) \cdot E_i^{\max} \cdot x_i^t \quad (34)$$

$$Q = (z^t \cdot \Theta_1(P) + (1 - z^t) \cdot \Theta_2(P) + S_{\text{HEX}}^t + S_{\text{load}}^t - S_{\text{WHS}}^t) / S^t \quad (35)$$

$$A_G^t = \left(\sum_{j=1}^p g_j y_j^t \right) \cdot Q \quad (36)$$

$$\begin{aligned} A_E^t &= z^t \cdot \Xi_1(P) + (1 - z^t) \cdot \Xi_2(P) \\ &+ \sum_{i=1}^q c_i^{\text{DAR}} x_i^t + \sum_{i=q+r+s+u+1}^{q+r+s+u+v} c_i^{\text{HEX}} x_i^t \\ &+ \sum_{i=1}^{q+r} c_i^{\text{CT}} x_i^t + \sum_{i=1}^{q+r} c_i^{\text{CP}} x_i^t + \sum_{i=1}^{q+r+s+u+v} c_i^{\text{P}} x_i^t \quad (37) \end{aligned}$$

In the formulation, $z^t = 1$ and $z^t = 0$ mean $P \leq 0.6$ and $P > 0.6$, respectively. In the following, let $\lambda^t = ((x^t)^T, (y^t)^T, z^t)^T$ and Λ^t be the feasible region of $P(t)$. Since an operating plan for one day is usually made at the DHC plant operation company every day, we should consider 24-hour operation plans $\lambda(0, 24) = ((\lambda^0)^T, (\lambda^1)^T, \dots, (\lambda^{23})^T) \in \Lambda(0, 24) = \Lambda^0 \times \dots \times \Lambda^{23}$. Sakawa et al. [7], [8], [4] studied multi-period operation-planning problems to reflect the practical situation for DHC plants. In such multi-period operation plans, we must consider equipment switching because equipment operating in a previous period may be stopping in the next period and vice versa. Since equipment start and stop require more electricity and labor than continuous operation, the arrangements cost of equipments should be taken into consideration in multi-period operation-planning.

We therefore formulate an extended operation-planning problem based on the arrangements cost of equipments. Specifically, we deal with the following problem, $P(0, 24)$, for 24-hour operation-planning:

Extended problem $P(0, 24)$

$$\begin{aligned} &\text{minimize} \\ &J_{0,24}(\lambda(0, 24)) = J(\lambda^0) + \\ &\sum_{\tau=1}^{23} \left[J(\lambda^\tau) + \sum_{j=1}^{p+q+r+s+u+v} \phi_j |\lambda_j^\tau - \lambda_j^{\tau-1}| \right] \quad (38) \end{aligned}$$

subject to

$$\lambda(0, 24) \in \Lambda(0, 24) \quad (39)$$

where ϕ_j is the cost of switching of the j -th equipment. Note that $P(0, 24)$ is a large nonlinear programming problem that involves 24 times as many variables as $P(t)$ does.

III. PENALTIES OF VIOLATION OF CONTRACTS

The DHC plant operating company has the following contracts in addition to the meter rate contracts with the electric power and gas company.

- **Minimum gas consumption contract** In the minimum consumption contract with the gas company, the amount of annual gas consumption must be greater than or equal to fixed B_1 . If this amount is less than B_1 , the DHC plant operating company must pay penalty M_1 to the gas company.

- **Maximum power contract** In the maximum power contract with the electric power company, the electric power must at any time be less than or equal to fixed B_2 . If this amount is greater than B_2 , the DHC plant operating company must pay penalty M_2 to the electric power company.

- **Peak-cut contract** The DHC plant operating company has a peak-cut contract with the electric power company, in which electric power must be less than or equal to fixed B_3 during peak power consumption from 13:00 to 16:00. If electric power exceeds B_3 during this period, the DHC plant operating company must pay penalty M_3 to the electric power company.

In short, the DHC plant operating company must pay a penalty if any contract is violated.

In the mathematical expressions for the above penalties, we consider maximum power contract penalty, $PE_2(\cdot)$, and that of the peak-cut contract, $PE_3(\cdot)$. One of these contracts is violated if electric power exceeds B_2 or B_3 , requiring payment of M_2 or M_3 , defined as;

$$PE_2(\lambda^t) = \begin{cases} M_2, & \text{if } A_E^t > B_2 \\ 0, & \text{otherwise} \end{cases} \quad (40)$$

$$PE_3(\lambda^t) = \begin{cases} M_3, & \text{if } A_E^t > B_3, t = 13, \dots, 16 \\ 0, & \text{otherwise.} \end{cases} \quad (41)$$

We next consider the minimum gas consumption contract. In order to check whether the minimum gas consumption contract is fulfilled or not exactly, a yearly operation plan is necessary. However, it takes enormous time to obtain the yearly operation plan since we need to a long-term (yearly) operation-planning problem which is large-scale. Thus, for the purpose of fast and approximately solving the long-term operation-planning problem, we propose a decomposition approach using coarse (monthly) approximate operation-planning problems. To be more specific, after setting a standard day for each month m , $m = 1, 2, \dots, 12$ whose 24-hour heat load is the average of those for all days in the month, we formulate and solve daily operation-planning problems corresponding to each of 12 standard days. Then, we calculate monthly gas consumption target values $B_{1,m}$, $m = 1, 2, \dots, 12$ on the basis of operation plans obtained by solving the daily operation-planning problems for standard days as:

$$B_{1,m} = B_1 \cdot \alpha_m + \frac{\sum_{\nu=1}^{m-1} (B_{1,\nu} - A_{G,\nu})}{12 - m + 1}$$

where B_1 is the threshold for the minimum gas consumption contract, α_m is the ratio of monthly to yearly gas consumption for month m (Fig.4) and $A_{G,\nu}$ is the monthly gas consumption for month ν with d_ν days defined as

$$A_{G,\nu} = d_\nu \sum_{\tau=0}^{23} \left(\sum_{j=1}^p g_j y_j^\tau \right) \cdot Q.$$

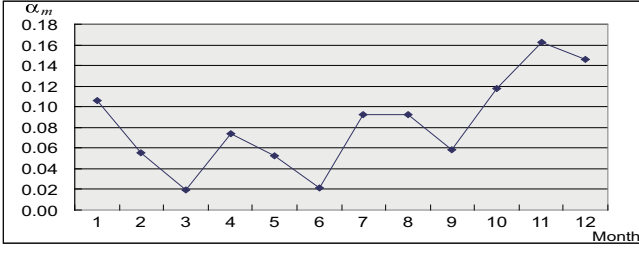

Fig. 4. The ratio of monthly to yearly gas consumption by month α_m .

Next, we define monthly penalties for the minimum gas consumption constraint $M_{1,m}$, $m = 1, 2, \dots, 12$ as:

$$M_{1,m} = M_1 \cdot \alpha_m$$

where M_1 is the penalty for the minimum gas consumption constraint violation.

Using $B_{1,m}$ and $M_{1,m}$, we also define daily gas consumption target values $B_{1,m}(d_m)$ and daily penalties $M_{1,m}(d_m)$ for the standard day of month m , $m = 1, 2, \dots, 12$ as follows.

$$B_{1,m}(d_m) = \frac{B_{1,m}}{d_m}$$

$$M_{1,m}(d_m) = \frac{M_{1,m}}{d_m}$$

Finally, we can define the penalty term for the minimum gas consumption constraint for 24-hour operation plan $\lambda_m(0, 24)$ for the standard day of month m as:

$$PE_1(\lambda_m(0, 24)) = \begin{cases} M_{1,m}(d_m) & , \sum_{\tau=0}^{23} A_G^\tau < B_{1,m}(d_m) \\ 0 & , \text{otherwise.} \end{cases}$$

Therefore, the coarse (monthly) approximate operation-planning problem for each month is formulated as follows. Monthly approximate operation-planning problem $P'_m(0, 24)$

$$\begin{aligned} & \text{minimize} \\ & J'_m(\lambda(0, 24)) = J_{0,24}(\lambda(0, 24)) + PE_1(\lambda(0, 24)) \\ & \quad + PE_2(\lambda(0, 24)) + PE_3(\lambda(0, 24)) \quad (42) \\ & \text{subject to} \\ & \lambda(0, 24) \in \Lambda(0, 24) \quad (43) \end{aligned}$$

After solving $P'_m(0, 24)$, $m = 1, 2, \dots, 12$, we estimate the yearly gas consumption by summing up monthly gas consumptions calculated from solutions to $P'_m(0, 24)$.

IV. NUMERICAL EXPERIMENT

We now consider the long-term (yearly) operation-planning for an actual DHC plant involving 1 type of boiler, 1 type of absorbing freezer, 1 type of turbo freezer, 1 type of cold water heat exchanger, 1 type of ice thermal storage tank heat exchanger and 1 type of heat exchanger. Concretely, we solve 12 coarse (monthly) approximate operation-planning problems $P'_m(0, 24)$ using a kind of tabu search based on strategic oscillation [2]. We conduct numerical experiments on a personal computer (CPU: Intel Pentium IV processor, 2.40GHz,

TABLE I
EXPERIMENTAL RESULTS FOR YEARLY OPERATION-PLANNING USING COARSE (MONTHLY) APPROXIMATE OPERATION-PLANNING PROBLEMS.

Results of 10 trials	Running cost with penalties (yen)	Average processing time (s)
Best	1.16×10^8	2.11×10^3
Average	1.19×10^8	
Worst	1.22×10^8	
Actual run	1.34×10^8	—

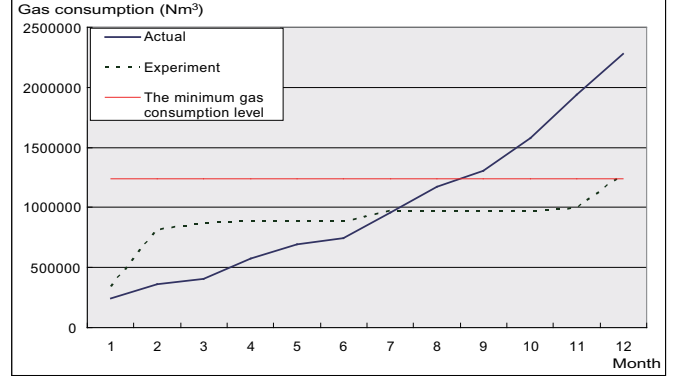

Fig. 5. The transition of gas consumption of the actual run and that of the operation plan obtained by solving $P'_m(0, 24)$, $m = 1, 2, \dots, 12$.

Memory: 512MB, C_Compiler: Microsoft Visual C++ 6.0) and the number of trials of tabu search is 10. Table I shows the best, average and worst values of yearly running cost with penalties calculated from 12 monthly operation plans obtained by solving $P'_m(0, 24)$, $m = 1, 2, \dots, 12$, found in 10 trials. In addition, the yearly running cost with penalties of the actual run is shown in Table I, the actual run is the result of the read operation by human operators in actual DHC plant. In Table I, it is shown that all running costs calculated from operation plans obtained by solving $P'_m(0, 24)$, $m = 1, 2, \dots, 12$ are less than the running cost of the actual run. This fact indicates that the effectiveness of the proposed approach.

Figure 5 shows the transition of gas consumption of the actual run and that of the operation plan obtained by solving $P'_m(0, 24)$, $m = 1, 2, \dots, 12$, which gives the best running cost in Table I, respectively. In the figure, the gas consumption of the actual run greatly exceeds the threshold for the minimum gas consumption contract, while that of the operation plan by the proposed approach exceeds it barely, i.e., economically.

V. CONCLUSION

In this paper, we focused on long-term operation-planning for district heating and cooling (DHC) plants involving utility-company contracts other than meter-rate contracts. First, we formulated two operation-planning problems - single-period $P(t)$ and multi-period $P(0, 24)$ as nonlinear integer programming problems. To fast and approximately solve long-term operation-planning problems, we propose a decomposition approach using coarse (monthly) approximate operation-planning problems. To be more specific, for given contract

violation penalties, we formulated an extended problem with penalties $P'_m(0, 24)$ corresponding to the standard day for each month. Furthermore, we demonstrated the effectiveness of the proposed approach by comparing the yearly running cost calculated from 12 monthly operation plans obtained by the proposed approach with the yearly running cost of the actual run. In the near future, we will extend our approach to multiobjective operation-planning for DHC plants.

REFERENCES

- [1] D. Henning, S. Amiri and K. Holmgren, *Modelling and optimisation of electricity, steam and district heating production for a local Swedish utility*, European Journal of Operational Research, Vol. 175, No. 2, pp. 1224–1247, 2006.
- [2] S. Hanafi and A. Freville, *An efficient tabu search approach for the 0-1 multidimensional knapsack problem*, European Journal of Operational Research, Vol. 106, No. 2–3, pp. 659–675, 1998.
- [3] K. Ito and R. Yokoyama, *Optimal planning of Co-Generation Systems*, Sangyo Tosho, 1990 (in Japanese).
- [4] K. Kato, M. Sakawa, K. Ishimaru and S. Ushiro, *Operation planning of district heating and cooling plants considering contract violation penalties*, Journal of Advanced Computational Intelligence and Intelligent Informatics, Vol. 13, No. 3, pp. 185–192, 2009.
- [5] K. Kato, M. Sakawa, K. Ishimaru, S. Ushiro and T. Shibano, *Heat load prediction through recurrent neural network in district heating and cooling systems*, Proceedings of 2008 IEEE International Conference on Systems, Man and Cybernetics (SMC 2008), pp. 1401–1406, 2008.
- [6] M. Sakawa, K. Kato and S. Ushiro, *Cooling load prediction in a district heating and cooling system through simplified robust filter and multi-layered neural network*, Applied Artificial Intelligence: International Journal, Vol. 15, No. 7, pp. 633–643, 2001.
- [7] M. Sakawa, K. Kato and S. Ushiro, *Operation planning of district heating and cooling plants through genetic algorithms for nonlinear 0-1 programming*, Computers & Mathematics with Applications, Vol. 42, No. 10–11, pp. 1365–1378, 2001.
- [8] M. Sakawa, K. Kato, S. Ushiro and M. Inaoka, *Operation planning of district heating and cooling plants using genetic algorithms for mixed integer programming*, Applied Soft Computing, Vol. 1, No. 2, pp. 139–150, 2001.
- [9] R. Yokoyama and K. Ito, *A revised decomposition method for MILP problems and its application to operational planning of thermal storage systems*, Journal of Energy Resources Technology, Vol. 118, pp. 277–284, 1996.